

# **BLUE** *line* INNOVATIONS

INNOVATIVE ENERGY SOLUTIONS



**THE POWERCOST MONITOR™**  
Quick Installation Guide

## Welcome!

Congratulations for having purchased your PowerCost Monitor™. This guide will show you how to install your PowerCost Monitor™ safely and start enjoying your electricity savings immediately.

By following the instructions in this Installation Guide, you will:

- Ensure that your PowerCost Monitor™ Display Unit and Sensor Unit operate as intended.
- Install your Sensor Unit on your meter.
- Synchronize your Display and Sensor Units together.
- Be ready to setup your Display Unit by following the instructions in the Setup Guide.

## Safety Precautions

Install your Sensor Unit on a dry day and please take all necessary precautions to install this product safely, more particularly if you need to use a ladder for installing the PowerCost Monitor™.

To ensure your PowerCost Monitor™ provides trouble-free service, please observe the following measures.

- Do not immerse the PowerCost Monitor™ in any liquid.
- Do not use the Display Unit in high moisture areas such as bathrooms.
- Place the Display Unit indoors only. Placing the Display Unit outdoors can result in damage to the product and will void the warranty.
- Keep this product away from heat sources such as stoves and heaters.
- Do not drop or cause any sudden impact to the PowerCost Monitor™.
- If disposing of this product, do so in accordance with your local waste disposal regulations.

# Step 1: Verify the contents and basic operation

## 1 Verify that your box contains all these components, then store the packing materials in a safe place:

- Display Unit
- Sensor Unit
- Rubber Shims (2)
- Clear Alignment Template (1)
- Installation Guide, Setup Guide and User Manual
- Alkaline “AA” Batteries (4)
- Installation DVD

## 2 Install the batteries in the Display Unit

Remove the Display Unit battery cover on the back of the unit, insert two alkaline “AA” batteries in the orientation indicated and replace the cover. You hear several beeps in rapid succession.

## 3 Install the batteries in the Sensor Unit

Open the Sensor Unit battery compartment by moving the cover latch to the unlocked position. Install the two AA alkaline batteries, with the battery closest to the Sensor Arm going in positive (+) end first. Close the cover and move the latch back to the locked position. The red **STATUS** indicator lights up.



## 4 Synchronize the Display and Sensor Units

This step ensures that both the Display Unit and Sensor Unit operate properly.

Press and hold the SYNC button on the front of the Display Unit until it beeps (approx. 3 seconds). The Display Unit displays this screen.



Press and release the RESET button on the battery cover of the Sensor Unit. The Display Unit now displays this screen.



## Step 2: Determine your meter type

Your utility meter is most probably located outside your house and it looks like one of the pictures on these two pages.

Your PowerCost Monitor™ Sensor Unit has been designed to fit on virtually any residential meter type, using its built-in clamping strap that goes over the meter dome. However, the installation procedure varies according to meter types. It is extremely important that you determine accurately what kind of meter is installed in your home before proceeding. Here are a few indications to help you.

There are two families of electrical meters:

- Electromechanical meters (with dials and a spinning disk with a black mark)
- Electronic meters (with a digital readout)

Electronic meters emit a light pulse signal through an optical port. The optical port can be located:

- On the front of the meter face
- On top of the meter.

Find the picture on the left side that looks like your meter. The picture next to it shows how your sensor should look when properly mounted.

*If you determine that your meter is one of the two following types, you can follow the procedures in this quick start guide to install your Sensor Unit.*

*Your meter looks like this...*

*...with the Sensor Unit mounted*



Electromechanical  
Meter

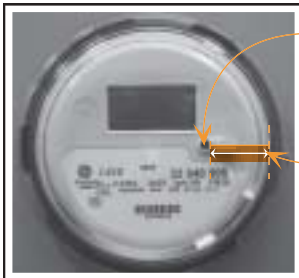

Optical Port

Electronic Meter  
Front Optical Port  
AT LEAST 1½ inches  
from outer rim of dome.  
If in doubt, physically  
measure the distance.



*If your meter is one of the following types, you can only install the Sensor Unit by following the instructions in the appropriate section in the supplied user guide*

*Your meter looks like this...*

*...with the Sensor Unit mounted*



Optical Port

**Electronic Meter**  
Front Optical Port  
LESS THAN 1½ inches  
from outer rim of dome.  
If in doubt, physically  
measure the distance.



See User Guide section 5.4



Optical Port

**Electronic Meter**  
Front Optical Port  
LESS THAN 1½ inches  
from outer rim of dome.  
If in doubt, physically  
measure the distance.



See User Guide section 5.4

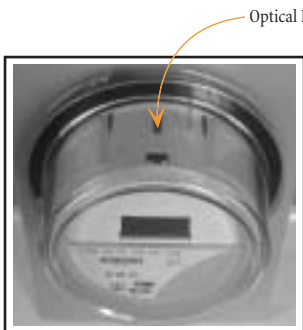

Optical Port

**Electronic Meter**  
Top Optical Port



See User Guide section 5.5

### Step 3 - Prepare your Sensor Unit

The Sensor Unit has two main parts: the fixed body and the movable Sensor Arm. The Sensor Head is located at the end of the Sensor Arm.

**IMPORTANT:** Please remember that your ultimate goal is to position the Sensor Head either inline with your electromechanical meter's spinning disk, or directly above your electronic meter's optical port.

Perform one of the two procedures below according to your meter type, and then go to the next step.

#### You have an electronic meter with the optical port on the face

Your Sensor Unit is delivered ready to install on your meter. However, it is recommended you pull the latch cover up to open it and verify that the Sensor Arm is **pushed in** as far as it will go into the body of the Sensor Unit.

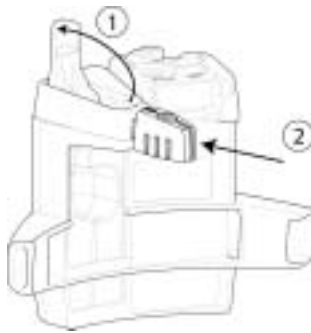

#### You have an electromechanical meter

- 1: Pull the latch cover upward to open it.
- 2: Extend the Sensor Arm to its full length by pulling on it. If you accidentally pull it out completely, push it back into the casing.
- 3: Close the latch cover.



## Step 4 - Install your Sensor Unit

When you are ready to install your PowerCost Monitor™ on your meter, you will need the following:

- This Guide
- Display Unit
- 1 large Flat Head screwdriver
- Stepping stool or ladder if your utility meter is located higher than eye level
- Clean damp cloth

**IMPORTANT:** Wipe the meter glass dome clean with the damp cloth before proceeding.

- 1: After adjusting the Sensor Arm length according to your meter type, fit the Sensor Unit over your utility meter as shown, so that the Sensor Head sits as close as possible to the front of the glass dome.

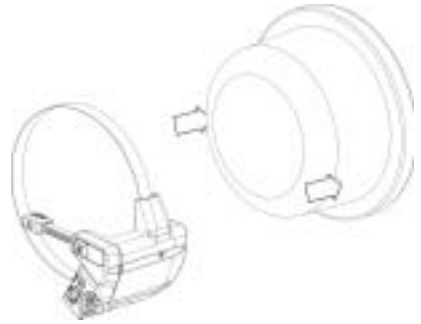

- 2: Tighten the hose clamp until the Sensor Unit is snug, but can move just enough to allow for slight adjustments.

- 3: Move the Sensor Unit assembly until the Sensor Arm is properly positioned on the meter:

On an **electromechanical meter**, the Sensor Head at the end of the Sensor Arm must be in line with the disk (use the line on the Sensor Arm as a reference) and centered from side-to-side.

Electromechanical Meter

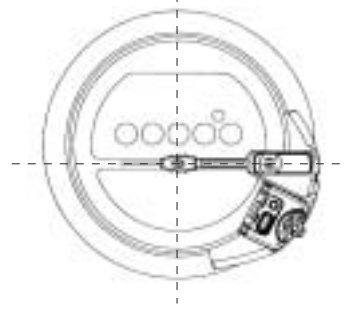

Electronic Meter

On an **electronic meter**, the head at the end of the Sensor Arm must be located exactly above the optical port.

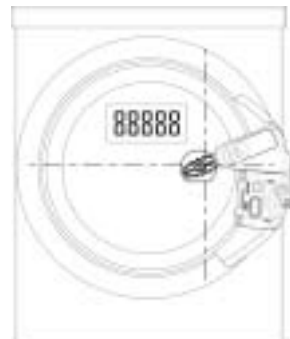

## Step 5 - Complete the installation

This procedure synchronizes the Sensor Unit and Display Unit, enabling you to program the Display Unit.

- 1: Press and release the **RESET** button on the battery cover of the Sensor Unit. On an **electromechanical meter**, the red indicator on the Sensor Unit lights up and stays lit for approximately 45 seconds, until the Sensor Unit has determined that it is installed on an electromechanical meter. The red STATUS indicator then flashes every time the black mark on the disk passes in front of the Sensor. On an **electronic meter**, the red indicator on the Sensor Unit lights up and stays lit until the Sensor Unit has determined that it is installed on an electronic meter. The red STATUS indicator then starts flashing irregularly.

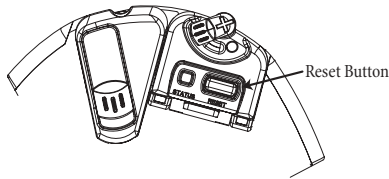

- 2: If the **STATUS** indicator does not react as described in Step 1, reposition your Sensor Unit slightly and repeat Step 1.
- 3: Make sure the Display Unit is on. Press and hold the **SYNC** button on the front of the Display Unit until it beeps (approx. 3 seconds). The Display Unit goes into ID Mode and it begins to search for your Sensor Unit.

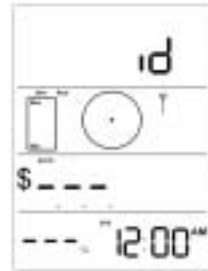

- 4: Press and release the **RESET** button on the battery cover of the Sensor Unit. The indicator light flashes and the Display Unit exits ID mode.
- 5: Tighten the hose clamp until the Sensor Unit cannot move easily. Do not over-tighten.

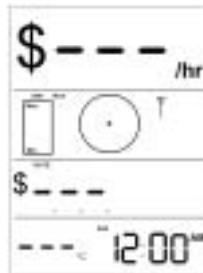

- 6: You can now program your Display Unit by following the instructions in the Setup Guide.