

OPEN FRAME Workstations - Modular Design System

Please read these guidelines carefully and follow the individual parts specific instructions.

Installation Procedures

Advantage 2000+ workstations features a modular concept along with a one piece welded upright frame allowing flexible equipment configurations and furniture solutions. Great Lakes offers eleven standard configurations in three widths, 26", 50", 72" (usable shelf width).

The basic construction consists of (2) Frame Uprights, (2) Braces & Covers, (1) 4-Point Mounting Shelf, which is the minimum required for a basic Open Frame unit assembly to stand alone. The basic construction of any size enclosure consists of (2) Frame Uprights, (2) Door Jambs, (1) Top Cover, (1) Bottom Cover, (2) Side Panels, (2) Doors or Door sets.

All components are mounted by the use of one type of screw and one tool. Worksurfaces and shelves can be mounted in one inch height increments. Slotted accessory shelves can be tilted to provide a more ergonomic environment. The flexible modular design allows you to add on to either side of a basic unit with the use of only one intermediate Frame Upright.

Electrical grounding is achieved through the Power Outlet Strips and your internal electrical system it plugs into. The Power Outlet Strips are rated at 15 amp, 120 volts with a resettable overload circuit breaker.

HARDWARE



Phillips Head Screw
#12-24 x 1/2" lg.

TOOL REQUIRED

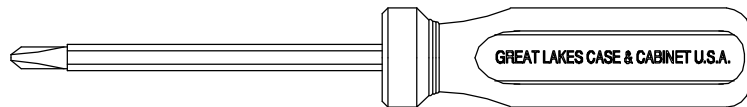

Phillips Head Screwdriver (provided)

The following is a general installation procedure in a step by step format for each category of specific types of parts. Refer to the detailed instructions for the specific category which is included with every part. The instruction # is located at the bottom of each detailed instruction sheet.

FOLLOW STEPS IN SEQUENCE:

1. **Frame Uprights** -----Instruction # 3BSCFRAME
2. **Structural Braces** -----Instruction # 6STRBRC
for **Inside Corner Braces** -----Instruction # 2CNRBRC
3. **Four Point Shelves** -----Instruction # 11-4PNT or # 8-4PNT
for **Four Point Worksurfaces** ----Instruction # 5FPWS
4. **Vertical Cable Management** -----Instruction # 3VCM
5. **Horizontal Cable Management** --Instruction # 3HCM
6. **Power Outlet Strips** -----Instruction # POWER
7. **Back Panels** -----Instruction # 3STRPNL
for **Inside Corner Back Panel** ---Instruction # 1CNRPAN
for **Modesty Panels** -----Instruction # 3MODPNL
8. If using Leveling Glides in the Frame Uprights, position assembly into position at this time.
9. **Cantilevered Shelves** -----Instruction # 9CNT
10. **The Optional Features not listed can now be installed at the customer's discretion.**

Refer to the Specific Instruction Sheets of each category for detailed assembly Instructions!

Frame Uprights & Structural Braces refers to figure - 1. Steps - 1 & 2

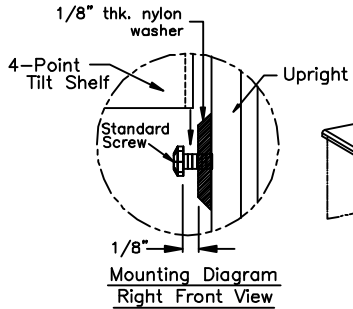
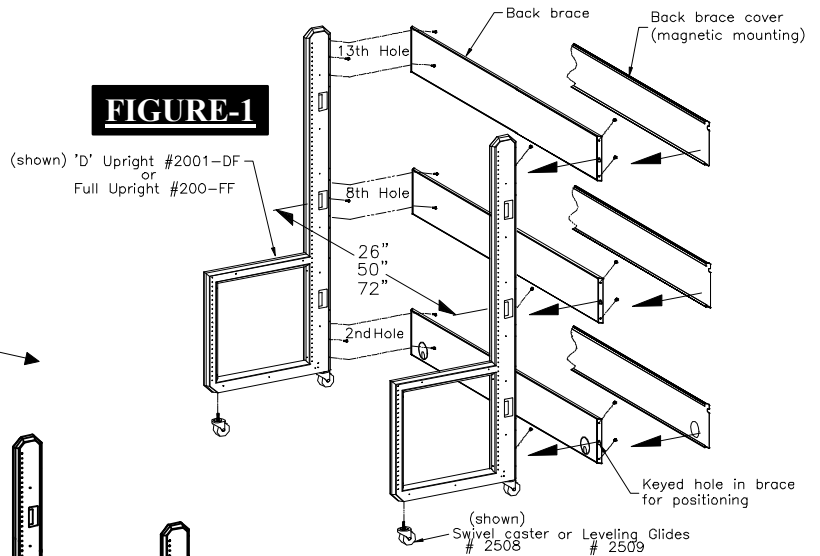
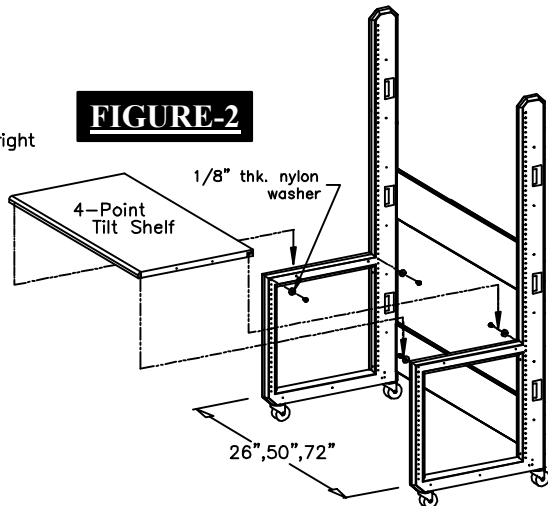

FIGURE-2



Four Point Shelves refers to figure - 2. Step - 3

Vertical Cable Management refers to figure - 3. Step - 4

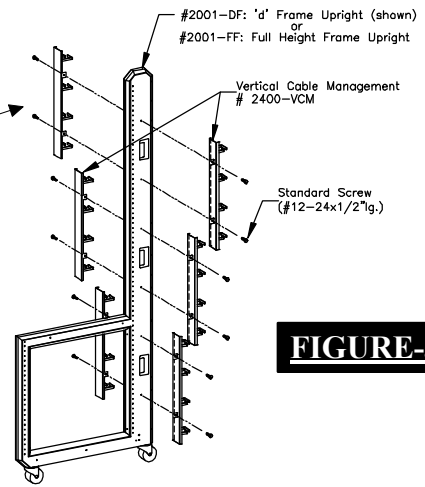

FIGURE-3

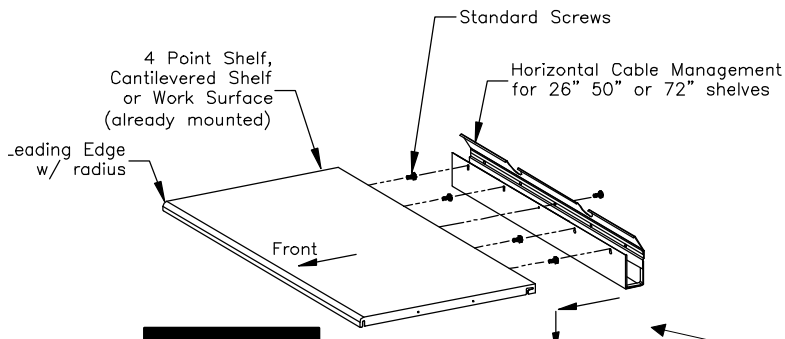

FIGURE-4

Horizontal Cable Management refers to figure - 4. Step - 5

Networking Advantage 2000+ OPEN FRAME Workstation is achieved by utilizing the threaded holes on the outside surface of the existing assembled Frame Uprights and one additional Frame Upright for each networked section. Networking Advantage 2000+ enclosures to other Advantage 2000+ enclosures as well as to OPEN FRAME Workstations is achieved by utilizing the same threaded holes. Advantage 2000+ Enclosures require the Full Height Frame Upright # 2001-FF.

Detailed Advantage 2000+ Enclosure assembly instructions can be found in Instruction numbers # 26WDCAB & # 50WDCAB.