

INSTRUCTION MANUAL

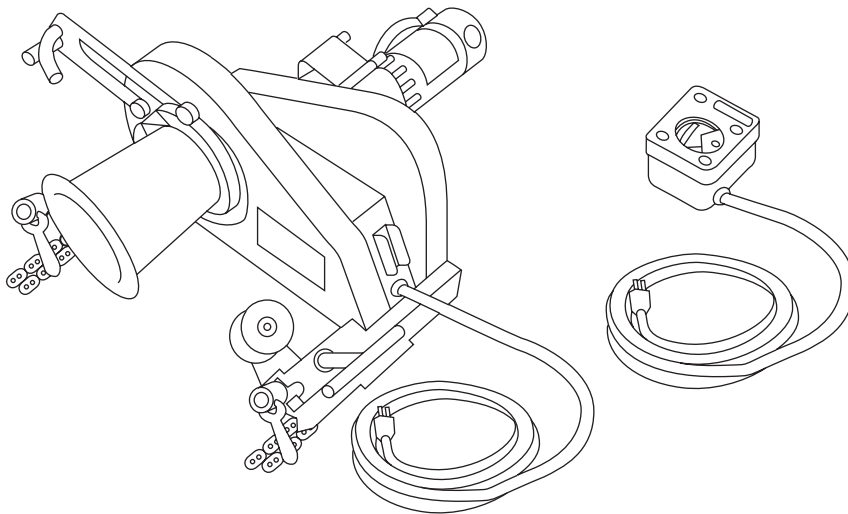

GREENLEE®

A Textron Company



640-Series Tugger® Cable Pullers

**Effective with Serial Code YJ for 115 Volt Pullers
and Serial Code ACR for 220 Volt Pullers**



Read and understand all of the instructions and safety information in this manual before operating or servicing this tool.

Table of Contents

Description	2
Purpose of this Manual	2
Important Safety Information	3-5
Grounding Instructions	6
Identification	7
Specifications	8
Cable Pulling Glossary	9
Cable Pulling Principles	10-18
Cable Pulling Systems	10
Pulling Theory	11
Cable Pulling Forces	12-16
Tailing the Rope	17
Summary of Cable Pulling Principles	18
Planning the Pull	18
Typical Setups	19-21
Setup and Operation	22-23
Removing Cable	24
Dual Pulling	25
Maintenance	26-28
Troubleshooting	29
Exploded Views and Parts Lists	30-39
Wiring Diagrams	40-41

Description

The Greenlee Tugger® cable puller is intended to be used to pull cable through conduit and in tray. The Tugger will develop 17.8 kilo-Newtons (4000 lb) of pulling force. See a Greenlee catalog for sheaves, pulling rope, and other cable pulling accessories rated for use with the Tugger to create an entire cable pulling system.

No single manual can provide instructions for every cable pulling application. This manual contains general information for pulling cable. Illustrations of some typical setups are also provided.

Safety

Safety is essential in the use and maintenance of Greenlee tools and equipment. This instruction manual and any markings on the tool provide information for avoiding hazards and unsafe practices related to the use of this tool. Observe all of the safety information provided.

Purpose of this Manual

This manual is intended to familiarize operators and maintenance personnel with the following Greenlee 640-series cable pullers:

120-Volt Models: 640 
642
676
686

220-Volt Models: 640-22
642-22
686-22

This manual should be kept available to operating and maintenance personnel.

All specifications are nominal and may change as design improvements occur. Greenlee Textron Inc. shall not be liable for damages resulting from misapplication or misuse of its products.

Mobilgrease is a registered trademark of Mobil Oil Corporation.

KEEP THIS MANUAL

IMPORTANT SAFETY INFORMATION



SAFETY ALERT SYMBOL

This symbol is used to call your attention to hazards or unsafe practices which could result in an injury or property damage. The signal word, defined below, indicates the severity of the hazard. The message after the signal word provides information for preventing or avoiding the hazard.

⚠ **DANGER**

Immediate hazards which, if not avoided, **WILL** result in severe injury or death.

⚠ **WARNING**

Hazards which, if not avoided, **COULD** result in severe injury or death.

⚠ **CAUTION**

Hazards or unsafe practices which, if not avoided, **MAY** result in injury or property damage.

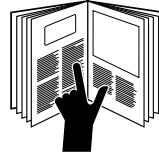

⚠ **DANGER**

Read and understand all of the instructions and safety information in this manual before operating or servicing this tool.

Failure to observe this warning will result in severe injury or death.



⚠ **DANGER**

Do not operate the cable puller in a hazardous environment. Hazards include flammable liquids and gases.

Failure to observe this warning will result in severe injury or death.



⚠ **WARNING**

Electric shock hazard:

Disconnect the cable puller from the power supply before servicing.

Failure to observe this warning could result in severe injury or death.

IMPORTANT SAFETY INFORMATION

	<p style="text-align: center;">⚠ WARNING</p> <p>Inspect all components of the cable-pulling system. Verify the maximum load-bearing capacity or maximum strength of all structural supports, pulling system components and anchoring systems before setting up the puller. Any component that cannot withstand the maximum cable-pulling forces may break and strike nearby personnel with great force.</p> <p>Failure to observe this warning could result in severe injury or death.</p>
---	---

	<p style="text-align: center;">⚠ WARNING</p> <p>Do not allow anything other than the pulling rope to contact the capstan. A grip, swivel, or other component could break and strike nearby personnel with great force.</p> <p>Failure to observe this warning could result in severe injury or death.</p>
--	--

	<p style="text-align: center;">⚠ WARNING</p> <p>Do not stand directly under a vertical pull. Cable could fall suddenly from the conduit, injuring nearby personnel.</p> <p>Failure to observe this warning could result in severe injury or death.</p>
---	---

<p style="text-align: center;">⚠ WARNING</p> <p>Do not operate puller if the anti-reverse mechanism is not working. If you do not hear the clicking of the anti-reversing pawl when the capstan is rotating, shut the puller off and have it repaired by an authorized Greenlee service center.</p> <p>Failure to observe this warning could result in severe injury or death.</p>

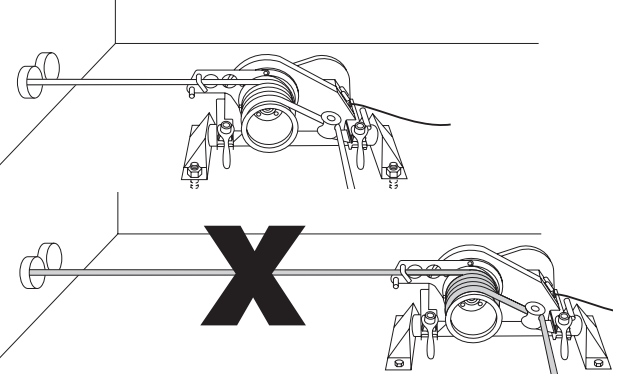
<p style="text-align: center;">⚠ WARNING</p> <p>Locate the puller so that it is close to the conduit. Rope, cable, or connectors can break under tension, causing the rope to whip violently.</p> <p>Failure to observe this warning could result in severe injury or death.</p>

<p style="text-align: center;">⚠ WARNING</p> <p>An under-rated rope may break and whip violently. Use a double-braided composite rope with the following characteristics:</p> <ul style="list-style-type: none"> • Maximum Rated Capacity: at least 17.8 kN (4000 lb) • Average Breaking Strength: at least 71.2 kN (16,000 lb) <p>Failure to observe this warning could result in severe injury or death.</p>

<p style="text-align: center;">⚠ WARNING</p> <ul style="list-style-type: none"> • Check the condition of the entire rope before use. A worn or damaged rope can break under tension and whip violently. • Do not maintain a stationary rope on a rotating capstan. The wear generated may cause the rope to break under tension and whip violently. <p>Failure to observe these warnings could result in severe injury or death.</p>

IMPORTANT SAFETY INFORMATION

⚠ WARNING

Attach the pulling rope to the cable with appropriate types of connectors as described in this manual. Select connectors with a maximum rated capacity of at least 17.8 kN (4000 lb). An under-rated connector can break under tension.

Failure to observe this warning could result in severe injury or death.



⚠ WARNING

Do not operate without chain guards in place.

Failure to observe this warning could result in severe injury or death.



⚠ WARNING

Keep hands away from the capstan. Rope at the capstan can crush a hand. Failure to observe this warning could result in severe injury or death.

⚠ WARNING

Use this tool for manufacturer's intended purpose only. Do not use the cable puller as a hoist or winch.

- The cable puller cannot lower a load.
- The load may fall.

Failure to observe this warning could result in severe injury or death.



⚠ WARNING

Do not wrap rope around hands, arms, waist or other body parts. Do not stand in spent coils or tailed rope. Hold rope so that it may be released quickly.

Failure to observe this warning could result in severe injury or death.

⚠ WARNING

Inspect puller and accessories before use. Replace any worn or damaged components with Greenlee replacement parts. A damaged or improperly assembled item can break and strike nearby personnel with great force.

Failure to observe this warning could result in severe injury or death.

⚠ WARNING

Rope, cable, or a connecting device can break under tension, causing the rope to whip violently.

- Do not allow any unnecessary personnel to remain in the area during the pull.
- Do not allow any personnel to stand in line with the pulling rope.

Failure to observe these warnings could result in serious injury or death.

⚠ WARNING

Entanglement hazard:

- Do not operate the cable puller while wearing loose-fitting clothing.
- Retain long hair.

Failure to observe these warnings could result in severe injury or death.

⚠ WARNING

Do not allow the rope to become overlapped on the capstan. If an overlap begins to develop, relax the tailing force immediately and shut off the cable puller.

Failure to observe this warning could result in severe injury or death.

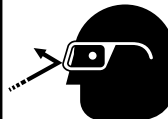

⚠ WARNING

Wear eye protection when using this tool.

Failure to wear eye protection could result in severe eye injury from flying debris.

Grounding Instructions

120-Volt Model

	⚠ WARNING
	<p>Electric shock hazard.</p> <ul style="list-style-type: none"> • Do not modify the plug provided with the tool. • Connect this tool to a grounded receptacle on a 20-amp GFCI-protected circuit. <p>Failure to observe these warnings could result in severe injury or death.</p>

220-Volt Model

	⚠ WARNING
	<p>Electric shock hazard.</p> <ul style="list-style-type: none"> • Do not modify the plug provided with the tool. • Connect this tool to a grounded receptacle on a 10-amp GFCI-protected circuit. <p>Failure to observe these warnings could result in severe injury or death.</p>

This tool must be grounded. In the event of a malfunction or breakdown, an electrical ground provides a path of least resistance for the electric current. This path of least resistance is intended to reduce the risk of electric shock.

This tool's electric cord has a grounding conductor and a grounding plug as shown. Do not modify the plug. Connect the plug to a corresponding receptacle that is properly installed and grounded in accordance with all national and local codes and ordinances. Do not use an adapter.

This tool must be grounded. In the event of a malfunction or breakdown, an electrical ground provides a path of least resistance for the electric current. This path of least resistance is intended to reduce the risk of electric shock.

This tool's electric cord has a grounding conductor and a grounding plug as shown. Do not modify the plug. Connect the plug to a corresponding receptacle that is properly installed and grounded in accordance with all national and local codes and ordinances. Do not use an adapter.

20 Amp/125 Volt Plug and Receptacle

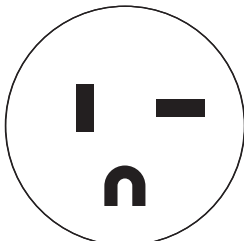

Plug

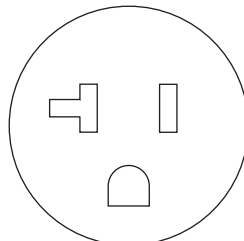

Receptacle

10 Amp/250 Volt Plug and Receptacle

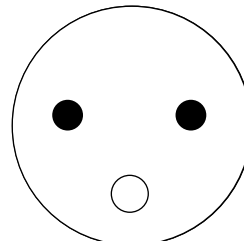

Plug

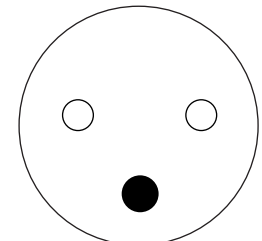

Receptacle

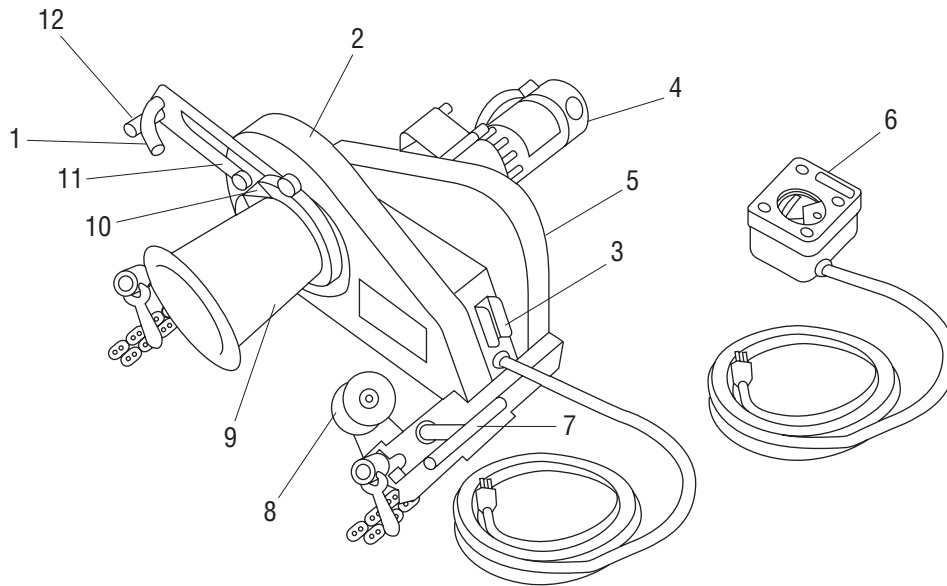
Identification**Tugger Identification**

- | | |
|--|-----------------------------|
| 1. Entrapment Peg | 7. Handle/Cleat |
| 2. Capstan Chain Guard | 8. Right-Angle Idler Sheave |
| 3. Guarded ON/OFF Switch and Circuit Breaker | 9. Tapered Capstan |
| 4. Motor | 10. Rope Ramp |
| 5. Motor Chain Guard | 11. Pivoting Capstan Arm |
| 6. Force Gauge with ON/OFF Switch (optional) | 12. Positioning Peg |

Specifications

Mass/Weight	30.8 kg (68 lb)
Dimensions:	
Length	533 mm (21")
Width	533 mm (21")
Height	305 mm (12")
Power (120-Volt Model)  :	
Voltage	120 VAC, 60 Hz
Current	17 Amps
Source	20 Amp GFCI-Protected Circuit
Power (220-Volt Model):	
Voltage	220 VAC, 50 Hz
Current	7.5 Amps
Source	15 Amp GFCI-Protected Circuit
Maximum Pulling Force	17.8 kN (4000 lb)
Speed:	
No load	10.7 meters/minute (35 feet/minute)
8900 Newtons (2000 lb)	4.88 meters/minute (16 feet/minute)
17.8 kN (4000 lb)	1.83 meters/minute (6 feet/minute)
Duty Cycle:	
0 - 11.1 kN (0 - 2500 lb)	Continuous Operation
11.1 - 15.6 kN (2500 - 3500 lb) (alarm will sound)	15 minutes on / 15 minutes off
15.6 - 17.8 kN (3500 - 4000 lb) (alarm will sound)	5 minutes on / 15 minutes off
Pulling Rope:	
Average breaking strength	71.2 kN (16,000 lb) minimum

Cable Pulling Glossary

anchoring system

any item or group of items that keeps a cable pulling component in place during the cable pull

capstan

the hollow cylinder of the cable puller that acts on the pulling rope to generate pulling force

coefficient of friction

the ratio that compares two amounts of force:
(1) the force needed to move an object over a surface and
(2) the force holding the object against the surface

This ratio is used to describe how the capstan and the rope work together.

connector

any item, such as a wire grip, clevis, swivel, or pulling grip, that connects the rope to the cable

direct line of pull

the areas next to the pulling rope and along its path; this includes the areas in front of, in back of, and underneath the rope

maximum rated capacity

the amount of pulling tension that any component can safely withstand, rated in kilo-Newtons (metric) or pounds; the maximum rated capacity of every component must meet or exceed the maximum pulling force of the cable puller

Newton

a metric unit of force, equivalent to .225 pounds of force

pipe adapter sheave

attaches to conduit for pulling or feeding cable

pulling grip

connects the rope to the cable; consists of a wire mesh basket that slides over the cable and grips the insulation

pulling force

the amount of pulling tension developed by the cable puller, rated in Newtons (metric) or pounds; a cable puller is usually described by the maximum pulling force that it can develop

resultant force

any force that is produced when two or more forces act on an object; applies to the sheaves of a cable pulling system

rope ramp

a device that works with a tapered capstan; guides the rope onto the capstan to help prevent rope overlap

sheave

a pulley that changes the direction of the rope and cable

stored energy

the energy that accumulates in the pulling rope as it stretches, described in Newtons-meters (metric) or foot-pounds

support structure

any stationary object that a cable pulling system component is anchored to, such as a concrete floor (for the floor mount) or an I-beam (for a sheave)

tail

the portion of the rope that the operator applies force to; this is the rope coming off of the capstan, and is not under the tension of the pull

tailing the rope

the operator's main function; this is the process of applying force to the tail of the pulling rope—see the complete explanation under Principles of Cable Pulling

wire grip

connects the rope to the cable; some use a set screw to clamp onto the conductors of the cable

Cable Pulling Principles

Pulling cable is a complex process. This section of the manual describes and explains four main topics of pulling cable:

- each cable pulling system component
- how these components work together
- forces that are generated
- procedures for the cable puller operator to follow

While reading through this section of the manual, look for components that are shaded in the illustrations. The shading indicates components that are associated with the text.

Greenlee strongly recommends that each member of the cable pulling crew review this section of the manual before each cable pull.

Cable Pulling Systems

Pulling cable requires a system of components. At a minimum, a cable pulling system will include a cable puller, a cable pulling rope, and connectors to join the rope to the cable. Most systems will also include, but are not limited to, a cable puller anchoring system, pulling sheaves and sheave anchoring systems.

The cable puller has a maximum amount of *pulling force*, which is the amount of pulling tension that it develops. Every other component of the pulling system has a *maximum rated capacity*, which is the amount of pulling tension that it can withstand. The maximum rated capacity of every component must meet or exceed the cable puller's maximum pulling force.

Typical Cable Pulling System

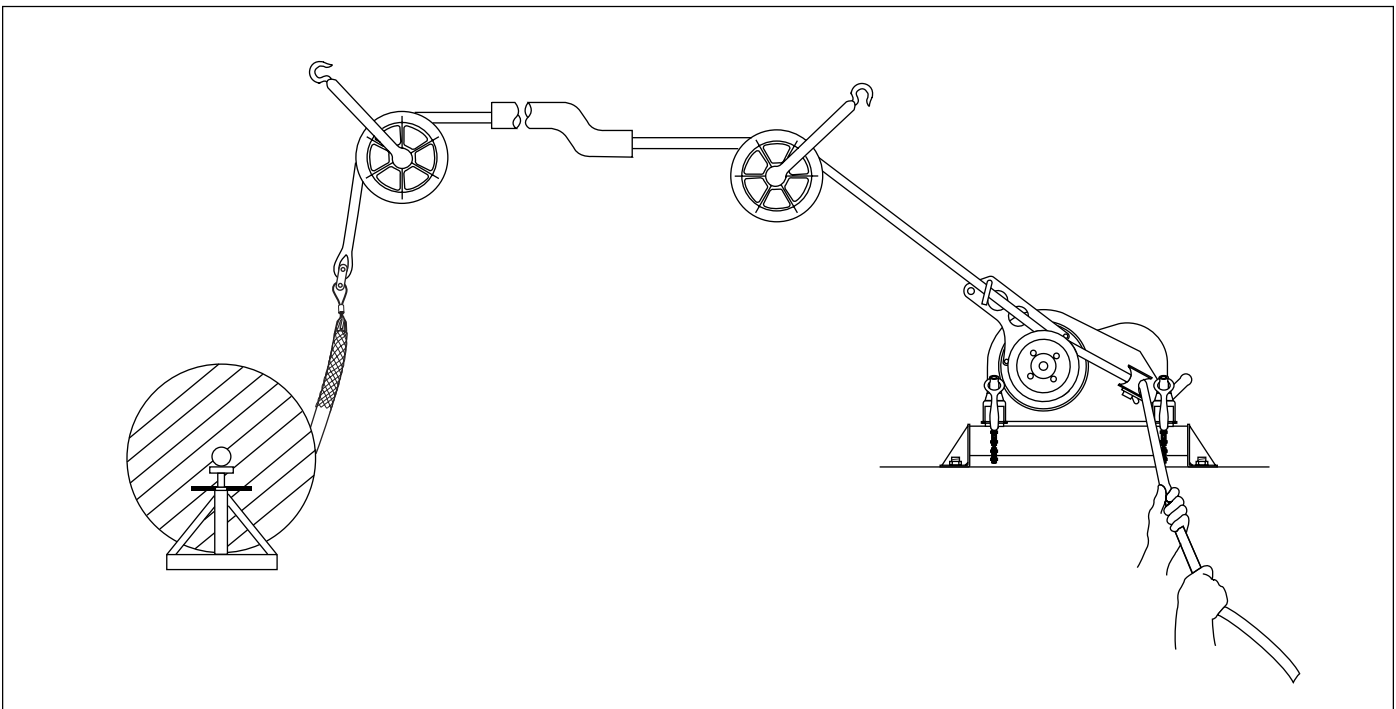

Cable Pulling Principles (cont'd)

Pulling Theory

This section introduces the main ideas involved with pulling cable.

Pulling Resistance

The cable puller must overcome two types of resistance: gravity and friction.

Gravity constantly exerts its force on the vertical portions of the run. When the pulling force is relaxed, gravity attempts to pull the cable downward. Friction develops where the cable contacts the sheaves, conduit and tray. Friction resists any movement, forward or backward, and tends to hold the cables in place.

To accomplish a cable pull, the cable pulling system must develop more force than the combination of gravity and friction.

Generating Pulling Force

To generate pulling force, the capstan works as a *force multiplier*. The operator exerts a small amount of force on the rope. The cable puller multiplies this and generates the pulling force.

This pulling force is applied to the rope, connectors, and cable in order to accomplish the pull. The direction of force is changed, where necessary, with pulling sheaves.

Cable Pulling Theory Illustrated

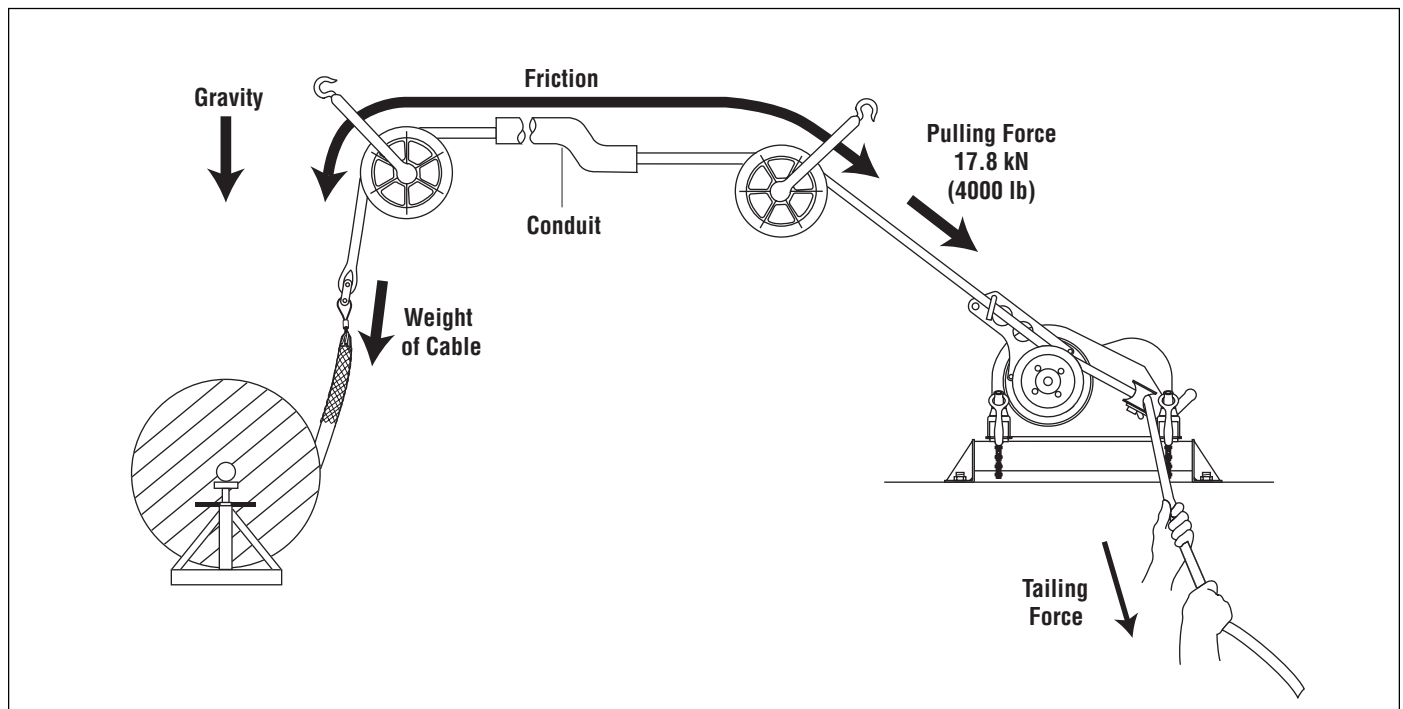

Cable Pulling Principles (cont'd)

Cable Pulling Forces

This section provides detailed explanations and illustrations of the forces that are generated during the cable pull. These explanations are based on the concepts presented in the previous section, Pulling Theory.

At the Cable Puller Anchoring System

The cable puller will exert its maximum pulling force on cable puller's anchoring system. It is extremely important the anchoring system can withstand this amount of force. See the instruction manual provided with your anchoring system for proper setup or installation.

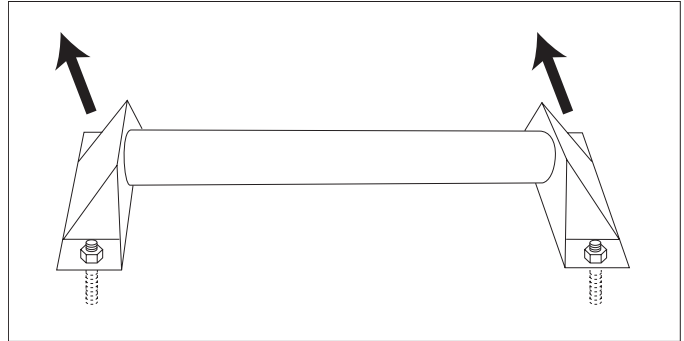

Pulling Force at the Cable Puller's Anchoring System

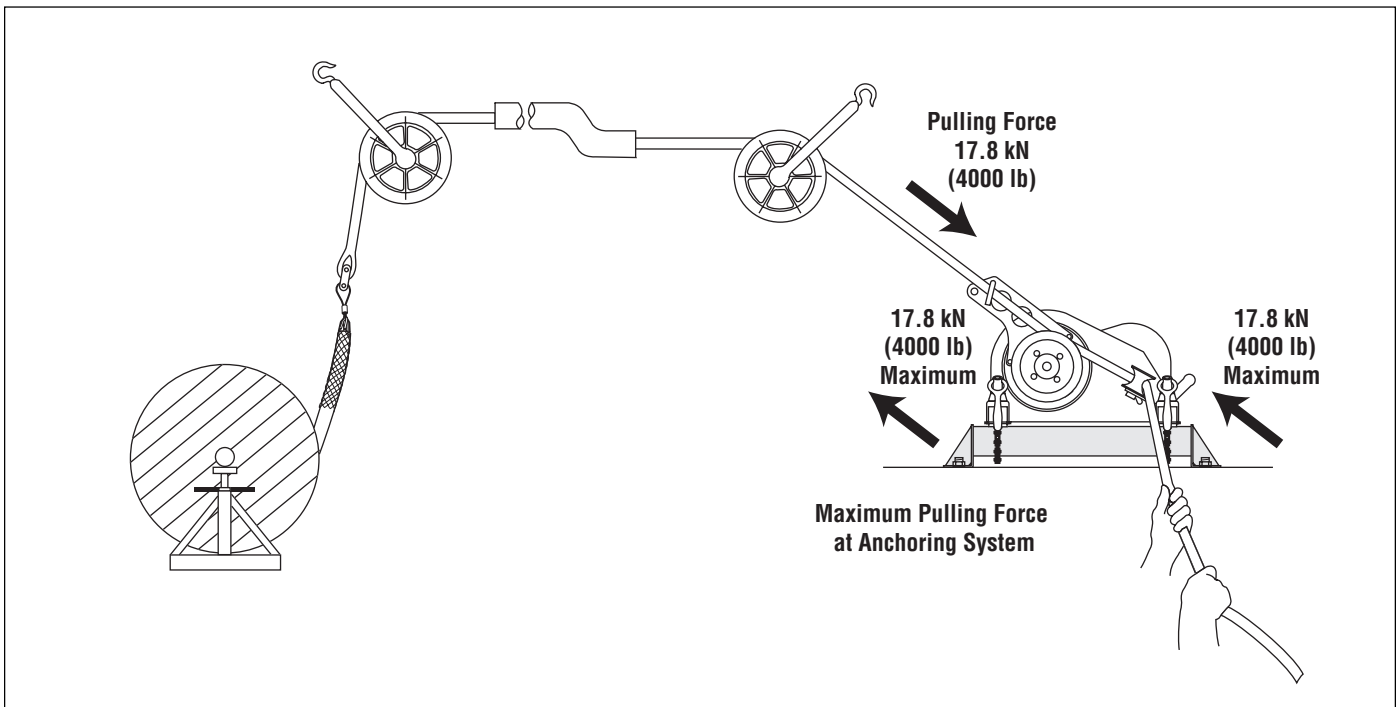

Cable Pulling Principles (cont'd)

Cable Pulling Forces (cont'd)

At the Capstan

The capstan acts as a *force multiplier*. The operator exerts a small amount of tension, or tailing force, on the rope; the capstan multiplies this force to pull the cable. The resultant force depends upon the number of times the rope is wrapped around the capstan, as shown in the formula below.

$$\text{Pulling Force} = \text{Tailing Force} \times e^{0.0175\mu\theta}$$

Where: e = the natural logarithm, or 2.7183

μ = the coefficient of friction between the rope and the capstan *

θ = the number of degrees of wrap of rope around the capstan

* The average value for the coefficient of friction when double-braided composite rope is pulled over a clean dry capstan is 0.125.

The following table is based on the formula above. The input, or tailing force, is constant at 44.5 Newtons (10 lb). Increasing the number of wraps increases the pulling force.

Operator's Tailing Force	Number of Wraps of Rope	Approximate Pulling Force
44.5 N (10 lb)	1	93.4 N (21 lb)
	2	213.5 N (48 lb)
	3	474.9 N (106 lb)
	4	1043.8 N (233 lb)
	5	2293.7 N (512 lb)
	6	5048.9 N (1127 lb)
	7	11.1 kN (2478 lb)

This table shows how the capstan acts as a force multiplier. Because the coefficient of friction depends upon the condition of the rope and capstan, this formula cannot determine an exact amount of pulling force.

The Capstan as a Force Multiplier

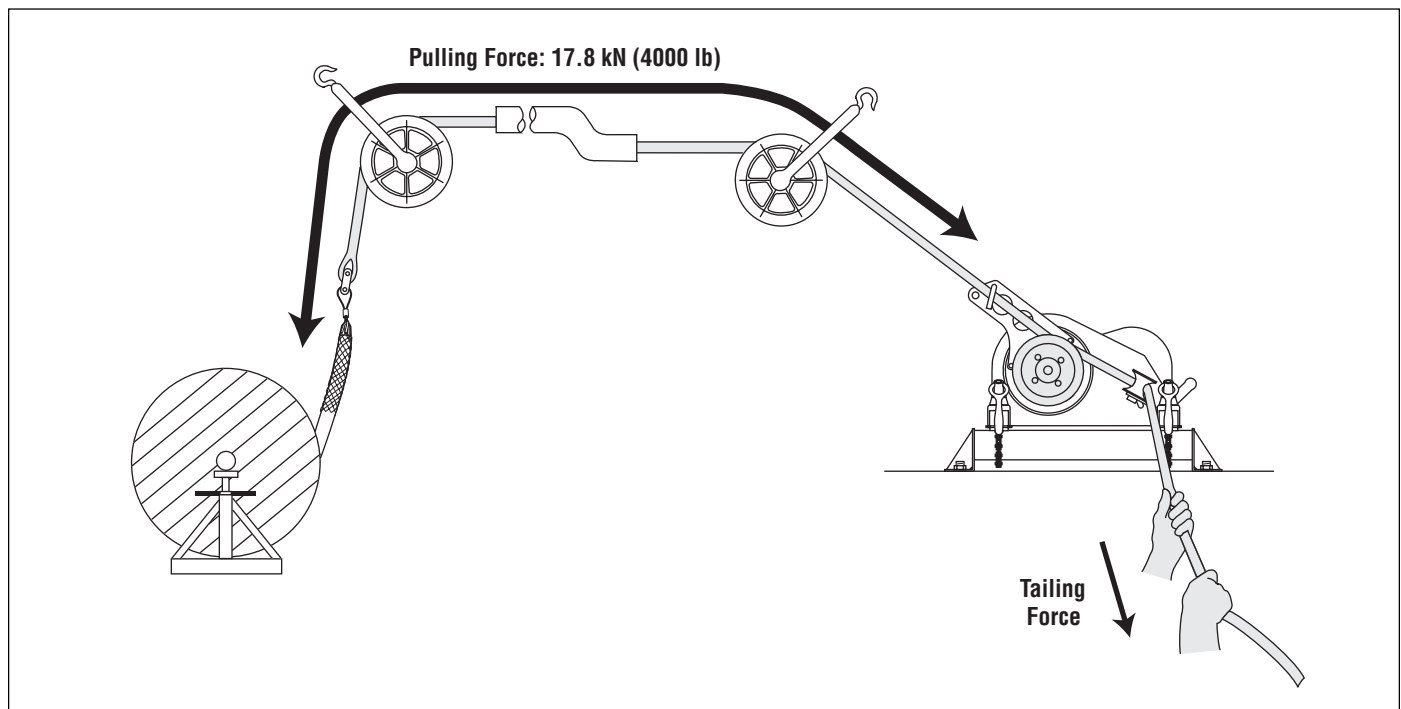

Cable Pulling Principles (cont'd)

Cable Pulling Forces (cont'd)

At the Pulling Rope

The product of a force (f) moving through a distance (d) is energy (f x d), and may be measured in Newton-meters or foot-pounds. Energy is stored in a rope when the rope is stretched. This is similar to the way energy is stored in a rubber band when it is stretched. Failure of the rope or any other component of the pulling system can cause a sudden uncontrolled release of the energy stored in the rope.

For example, a 100-meter nylon rope with a 50,000 Newton average breaking strength could stretch 40 meters and store 1,000,000 joules of energy. This is enough energy to throw a 900-kilogram object, such as a small automobile, 113 meters into the air.

A similar double-braided composite rope could store approximately 300,000 joules of energy. This could throw the same object only 34 meters into the air. The double-braided composite rope stores much less energy and has much less potential for injury if it were to break.

Double-braided composite rope is the only type of rope recommended for use with the Tugger cable puller. Select a double-braided composite rope with an average rated breaking strength of at least 71.2 kN (16,000 lb).

Stored Energy

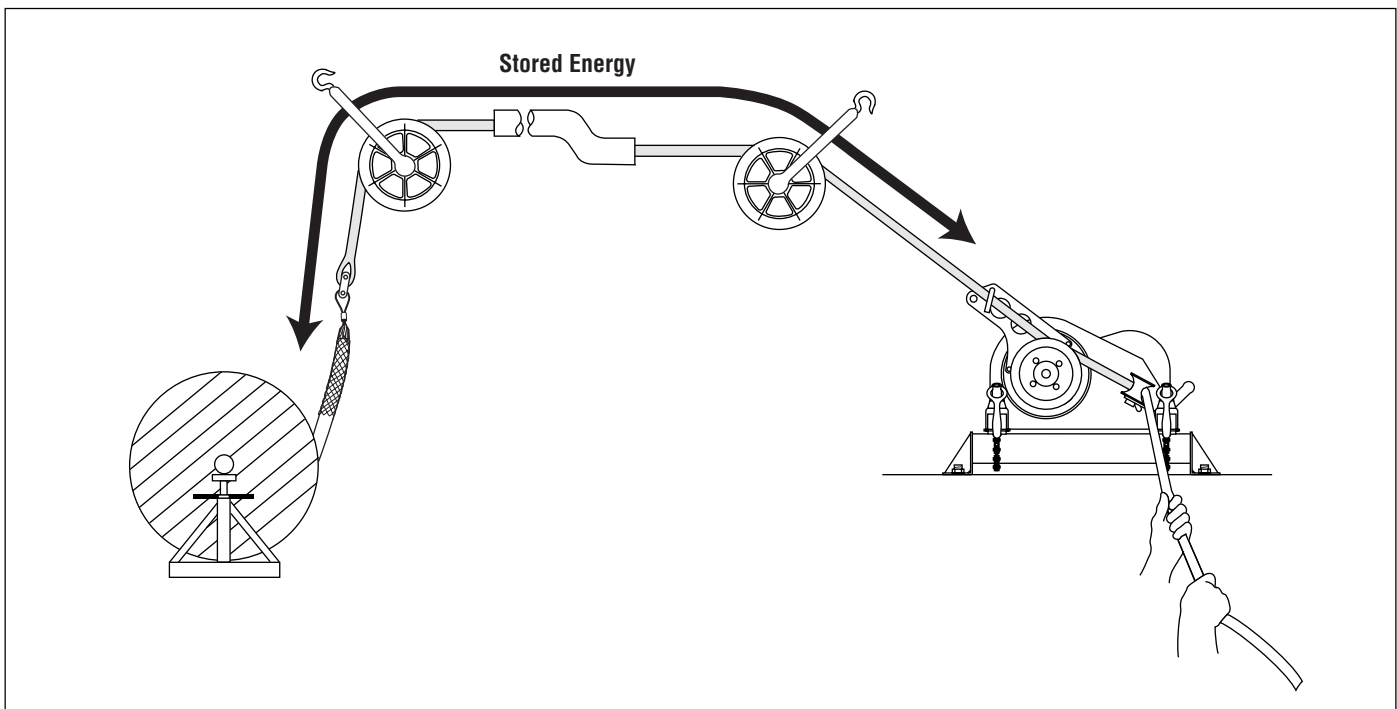

Cable Pulling Principles (cont'd)

Cable Pulling Forces (cont'd)

At the Connectors

The connectors will be subjected to the cable puller's maximum pulling force.

Several types of rope connectors—clevises, swivels, and rope-to-swivel connectors—are available. Follow the instructions provided with each to provide a good connection.

Two types of wire connectors—wire grips and pulling grips—are available. The wire grip uses a set screw to clamp onto the conductors of the cable. The pulling grip consists of a wire mesh basket that slides over the cable and grips the insulation.

When selecting a pulling grip, it is extremely important to select a grip of the correct (1) type, (2) size, and (3) maximum rated capacity.

1. Select the correct type based on the descriptions of each type in the Greenlee catalog.
2. Measure the circumference of the wire bundle. (To do this accurately, fasten a tie strap around the bundle. Cut off and discard the tail. Then cut the tie strap and measure its length.) Use the table provided to find the correct size.
3. See the maximum rated capacities in the Greenlee catalog.

A Typical Grip Setup—Clevis and Wire Grip

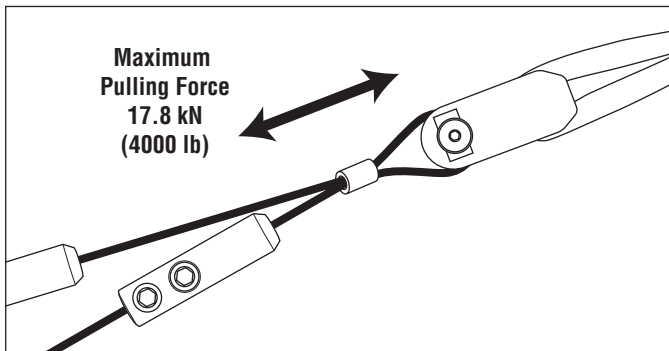

A Typical Grip Setup—Swivel and Pulling Grip

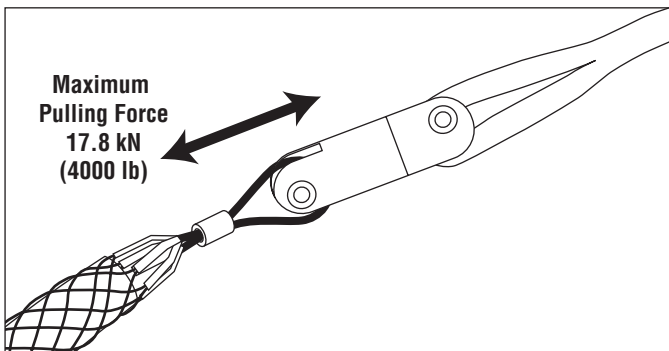

Pulling Grip Size Table

Circumference Range		Required Grip Diameter	
inches	mm	inches	mm
1.57 - 1.95	39.9 - 49.5	0.50 - 0.61	12.7 - 15.5
1.95 - 2.36	49.5 - 59.9	0.62 - 0.74	15.8 - 18.8
2.36 - 3.14	59.9 - 79.8	0.75 - 0.99	19.1 - 25.1
3.14 - 3.93	79.8 - 99.8	1.00 - 1.24	25.4 - 31.5
3.93 - 4.71	99.8 - 119.6	1.25 - 1.49	31.8 - 37.8
4.71 - 5.50	119.6 - 139.7	1.50 - 1.74	38.1 - 44.2
5.50 - 6.28	139.7 - 159.5	1.75 - 1.99	44.5 - 50.5
6.28 - 7.85	159.5 - 199.4	2.00 - 2.49	50.8 - 63.2
7.85 - 9.42	199.4 - 239.3	2.50 - 2.99	63.5 - 75.9
9.42 - 11.00	239.3 - 279.4	3.00 - 3.49	76.2 - 88.6
11.00 - 12.57	279.4 - 319.3	3.50 - 3.99	88.9 - 101.3
12.57 - 14.14	319.3 - 359.2	4.00 - 4.49	101.6 - 114.0
14.14 - 15.71	359.2 - 399.0	4.50 - 4.99	114.3 - 126.7

Cable Pulling Principles (cont'd)



Cable Pulling Forces (cont'd)

At the Sheaves

Sheaves are used to change the direction of the pull. A change in direction creates a new *resultant force* that is *greater than* the cable puller's maximum pulling force. This new resultant force exerts itself on the sheaves, sheave anchoring system, and support structures illustrated.

The resultant amount of force depends on the angle of the change in direction. A brief table is provided here; for more details, see IM 1363 (99929988).

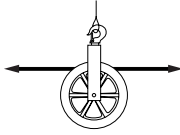
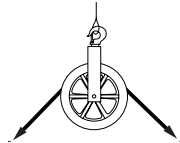
Resultant Force Table for the Tugger
(17.8 kN or 4000 lb Maximum Pulling Force)

Illustration	Angle of Change in Direction	Resultant Force in kN (lb)
	180°	0 (0)
	150°	9.25 (2080)
	135°	13.7 (3080)
	120°	17.8 (4000)
	90°	25.1 (5640)
	60°	30.8 (6920)
	45°	32.9 (7400)
	30°	34.3 (7720)
	0°	35.6 (8000)

Typical Resultant Force at Sheave

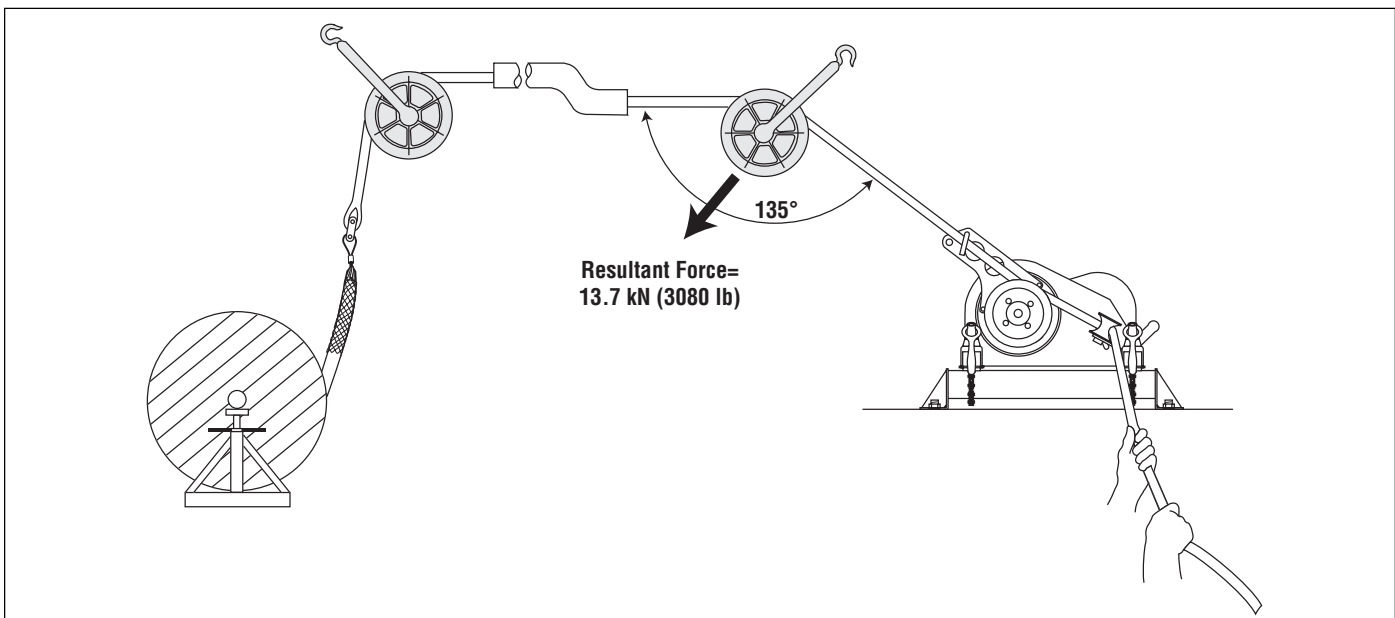

Cable Pulling Principles (cont'd)

Tailing the Rope

The rope must be pulled off of the capstan as the pull progresses. The rope that has left the capstan is the “tail.” The process of pulling the rope off of the capstan is called *tailing the rope*.

The resistance of the cable varies throughout the duration of the cable pull. Changes in resistance are due to characteristics of the rope, changes in conduit direction, and changes in the amount of friction. The “feel” of the rope provides this information about the pull. This is called *tactile feedback*. Adjust the tailing force as necessary to compensate for these changes.

Control of the Pull

Decreasing the tailing force will decrease the pulling force, until the rope slips on the capstan and the pull stops. This provides a high level of control over the progress of the cable pull.

Do not allow the rope to slip on the capstan for more than a few moments. If it becomes necessary to completely stop a pull, shut off the puller and maintain enough tailing force to hold cable in place. Tie the rope off to hold it in place.

Amount of Tailing Force

While the rope and cable are under tension, it is important to maintain the proper amount of tailing force.

Too little tailing force will allow the rope to slip on the capstan. This will build up excessive heat and accelerate rope wear, increasing the possibility of breaking the rope.

The proper amount of tailing force will stop the rope from slipping on the capstan and produce a sufficient amount of pulling force to pull in the rope and cable.

Too much tailing force is any amount more than is necessary to stop the rope from slipping on the capstan. Excessive tailing force will not increase the pulling force or pulling speed.

Number of Wraps of Rope Around the Capstan

An experienced operator should choose the number of times the rope is wrapped around the capstan.

The proper number of wraps allows the operator to control the progress of the pull with a comfortable amount of effort.

Using *too few wraps* requires a large tailing force to accomplish the pull. Using too few wraps also makes the rope more likely to slip on the capstan. This builds up heat and accelerates rope wear.

Using *too many wraps* causes the rope to grab the capstan more tightly. This accelerates rope wear, wastes power, and increases the possibility of a rope overlap. Using too many wraps also reduces tactile feedback, so you receive less information about the pull. You cannot quickly relax the tailing force when there are too many wraps.

If the rope becomes difficult to tail, add another wrap of rope. Turn off the puller and release all of the tension in the rope. Add a wrap and resume pulling. Be aware, however, that some pulls will require tension to hold the cables in place. In these cases, do not attempt to release all of the tension and add a wrap of rope. You will need to anticipate the number of wraps before starting the pull.

Preventing Rope Overlap

Do not allow the rope to become overlapped on the capstan during a pull.

A rope overlap will make it impossible to continue or back out of the pull.

If the rope becomes overlapped, you will lose control of the pull—the rope will advance with no tailing force and will not feed off of the capstan. The capstan will not allow you to reverse the direction of the rope, so you cannot back out of an overlap.

Set up the puller properly. The positioning peg, entrapment peg, rope ramp and tapered capstan are intended to prevent rope overlap. See the instructions in the Operation section of this manual.

Every wrap of the rope must remain in direct contact with the capstan. During the pull, take great care to prevent the incoming rope from riding up and overlapping the next wrap. If an overlap begins to develop, immediately relax the tailing force on the rope so that the rope can feed back toward the conduit or tray. When the rope resumes its normal path, apply tailing force and continue the pull.

There is no suggested remedy for a rope overlap.
Do not allow the rope to overlap!

Cable Pulling Principles (cont'd)

Summary of Cable Pulling Principles

- A cable pulling system consists of many components that work together to accomplish a pull.
- The cable puller is rated by its maximum pulling force; every other component is rated by its maximum rated capacity. The maximum rated capacity of every component must meet or exceed the maximum pulling force of the cable puller.
- The cable puller must overcome two types of resistance: gravity and friction. The puller's capstan, the pulling rope, and the operator tailing the rope work together to produce pulling force.
- The cable puller exerts force on every component of the cable pulling system, including the anchoring systems and the support structures.
- Energy is stored in a rope when the load causes the rope to stretch. Failure of the rope or any other component can cause a sudden release of energy. Replace any rope that is worn or damaged.
- Carefully select the number or wraps of rope around the capstan before starting the pull.
- Control the pull by tailing the rope. Be familiar with the interaction of the rope and capstan.
- Do not allow a rope overlap to develop.

Planning The Pull

- Pull in a direction that will require the lowest amount of pulling force.
- Plan several shorter pulls rather than fewer longer pulls.
- Locate the puller as close to the end of the conduit as possible to minimize the amount of exposed rope under tension.
- Place each component so that the pulling forces are used effectively.
- Select an anchoring system: adapter sheaves, which are preferred, or the floor mount.
- Verify that each component has the proper load rating.
- Inspect the structural supports. Verify that they have enough strength to withstand the maximum forces that may be generated.

Typical Setups—using 11147 Adapter Package

Setups are shown without force gauge. Place the force gauge so the operator has an unobstructed view of the meter and quick access to its ON/OFF switch.

**Pulling Horizontally in Manhole
Using Two Booms, Nose Unit,
Elbow Unit and Slip-in Coupler**

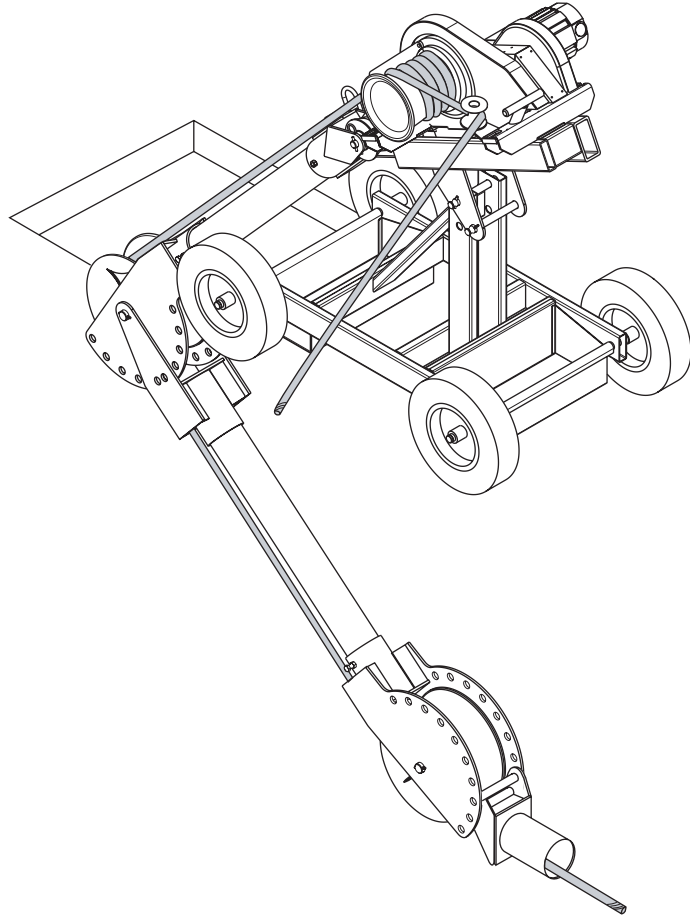

**Pulling Horizontally in Manhole
Using Two Booms, Nose Unit,
Elbow Unit and Slip-in Coupler**

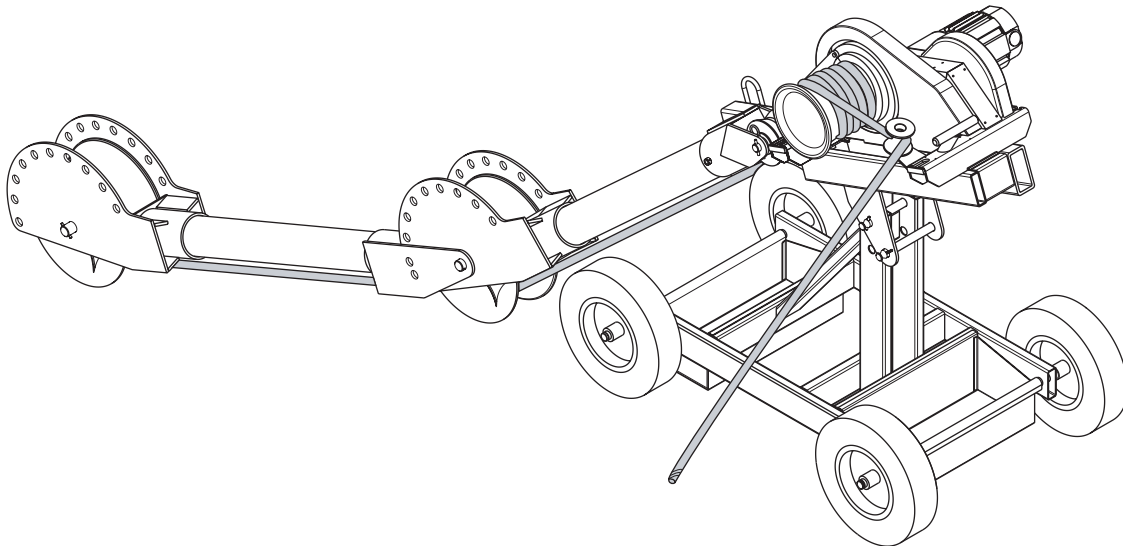

Typical Setups—using 11147 Adapter Package (cont'd)

Setups are shown without force gauge. Place the force gauge so the operator has an unobstructed view of the meter and quick access to its ON/OFF switch.

**Pulling Up Using One Boom,
Nose Unit and Slip-in Coupler**

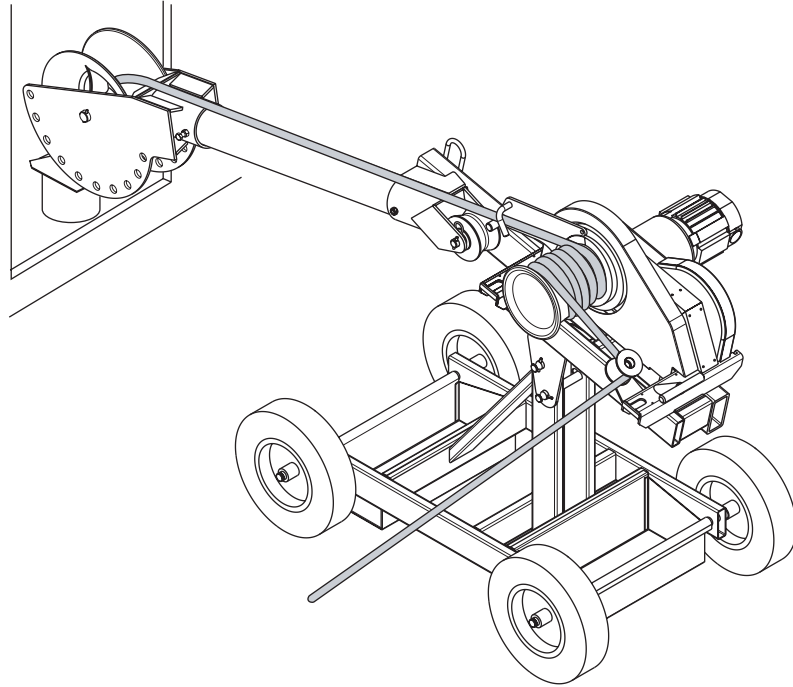

**Pulling Up Using Two Booms, Nose Unit,
Elbow Unit and Slip-in Coupler**

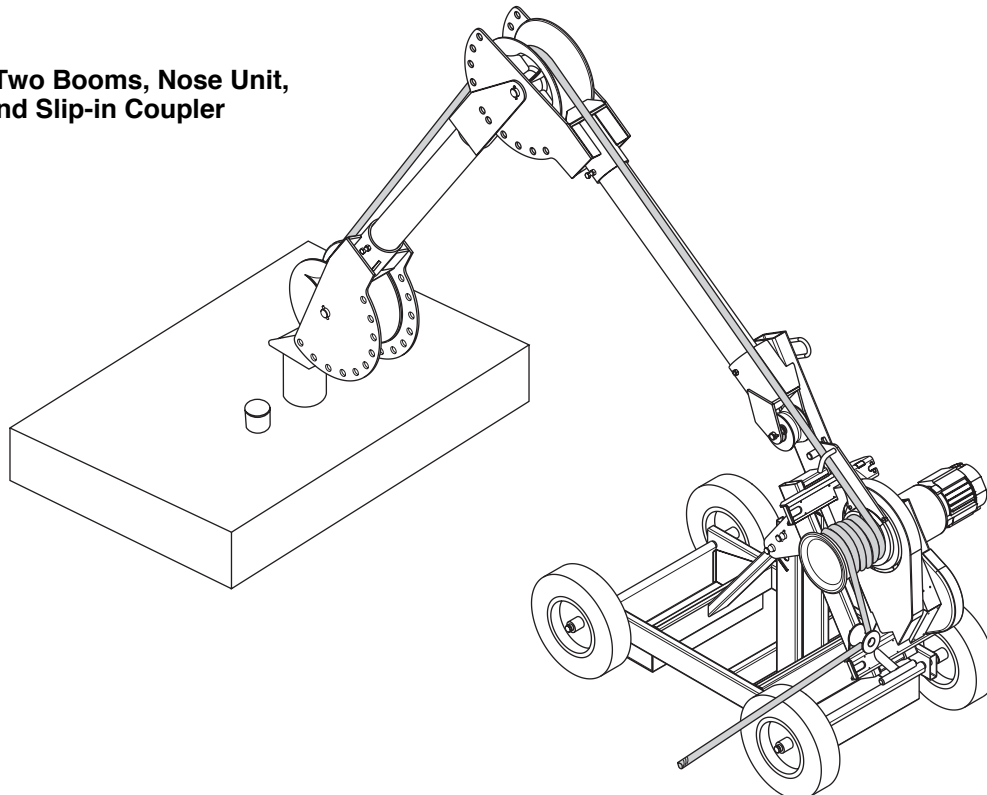

Typical Setups (cont'd)

Setups are shown without force gauge. Place the force gauge so the operator has an unobstructed view of the meter and quick access to its ON/OFF switch.

Using a Manhole Sheave

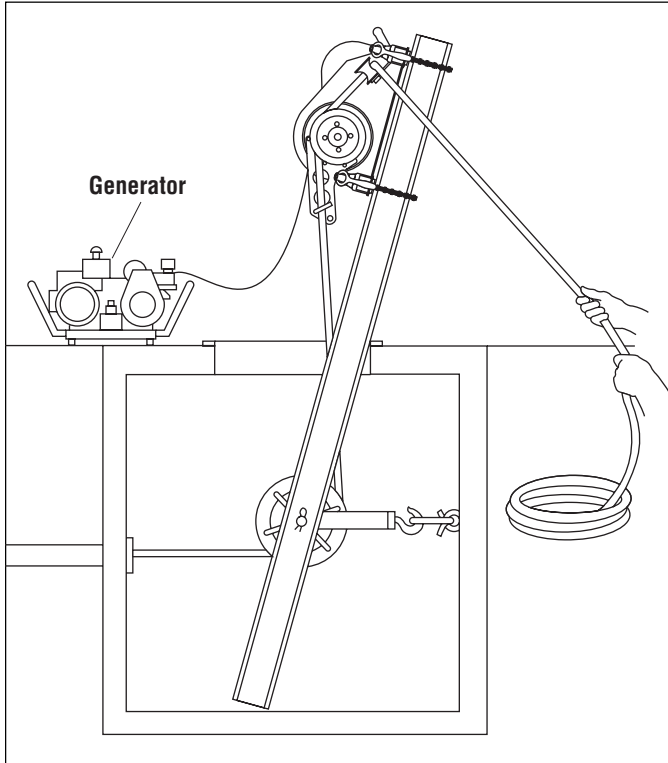

Using Feeding Sheaves in Manholes

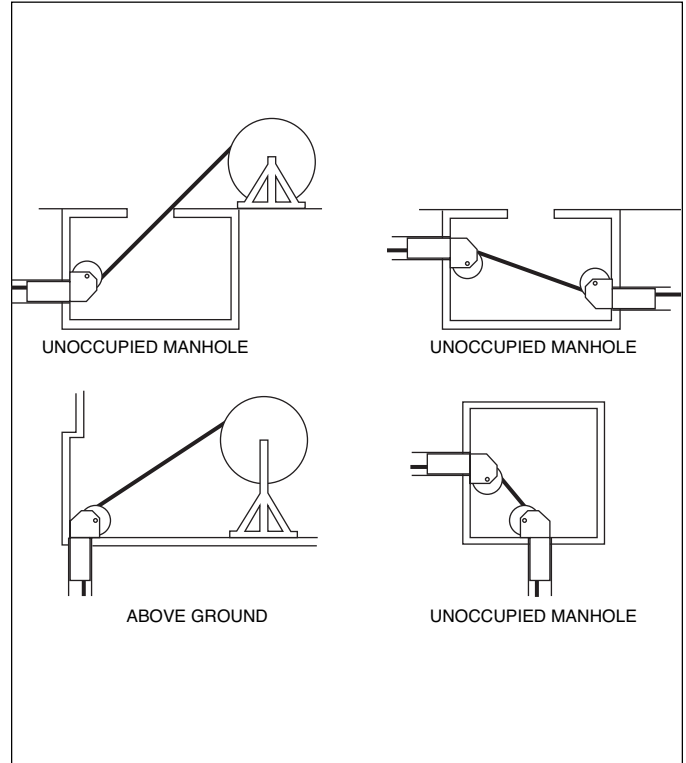

Using a Floor Mount

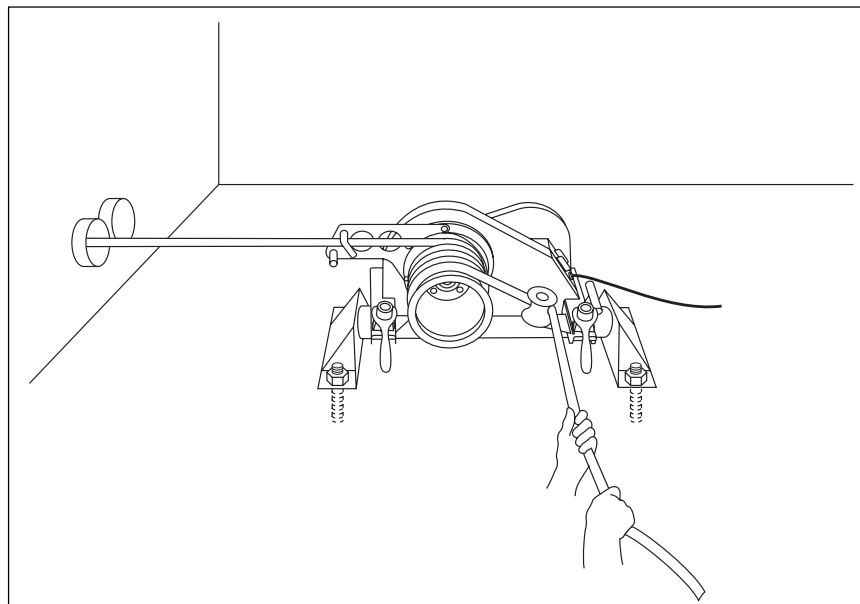

Setup and Operation

While reading through this section of the manual, look for components that are shaded in the illustrations. The shading indicates components that are associated with the accompanying text.

1. Fish the rope through the conduit.
2. Set up the cable puller mounting. Set it up so that the rope will approach the capstan at an angle of $90^\circ (\pm 5^\circ)$ as illustrated in Rope Approaching the Capstan.

Note: If using an adapter sheave, flexible pipe adapter, or mobile T-boom, see the illustrations in this manual. If using a manhole sheave or floor mount, see the instructions supplied with those items.

Rope Approaching the Capstan

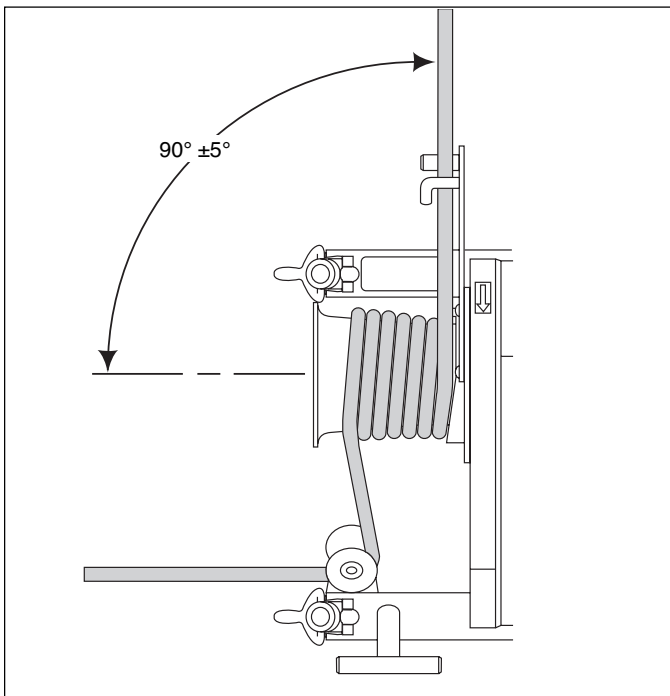

⚠ WARNING

Install the vise chains properly.

- Follow the vise chain tightening instructions carefully. Improperly tightened chains can allow the puller to slide or break loose and strike nearby personnel.
- Do not allow the vise chains to bind at the corners when mounting the puller to a square or rectangular support. The vise chain must be uniformly tight at all points.

Failure to observe this warning could result in severe injury or death.

3. Install the vise chains as shown.

Vise Chain Installation

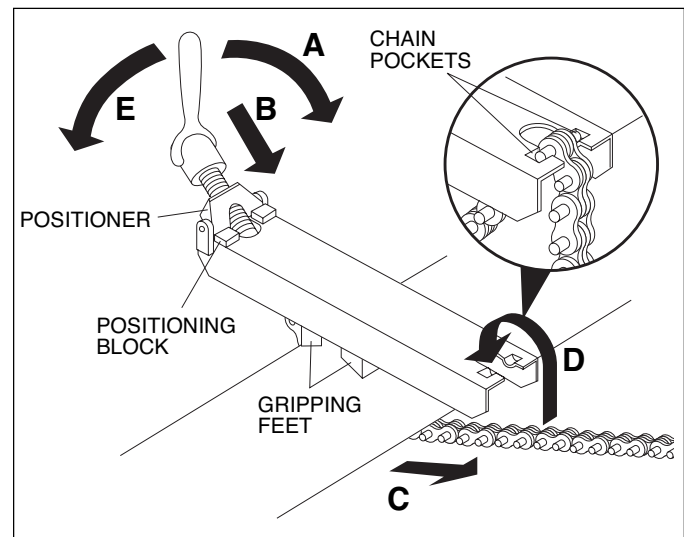

⚠ WARNING

When setting up the flexible pipe adapter or puller, do not use the vise chains on a structural support that is less than 51 mm (2") or more than 254 mm (10") wide. An oversized or undersized structural support can allow the puller to slide or break loose and strike nearby personnel with sufficient force to cause severe injury or death.

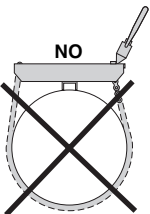
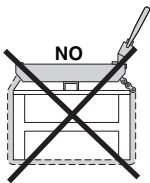

Setup and Operation (cont'd)

5. Align the rope ramp and route the rope as illustrated in Rope Path, Top View and Rope Path, Side View.

Note: Use every component of the rope path—the positioning peg, entrapment peg, rope ramp and tapered capstan—as shown to help prevent rope overlap.

Rope Path, Top View

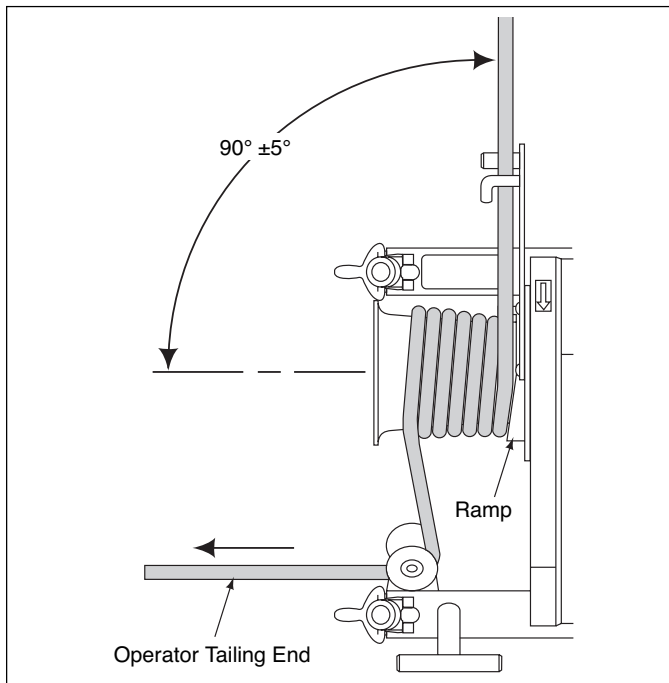

Rope Path, Side View

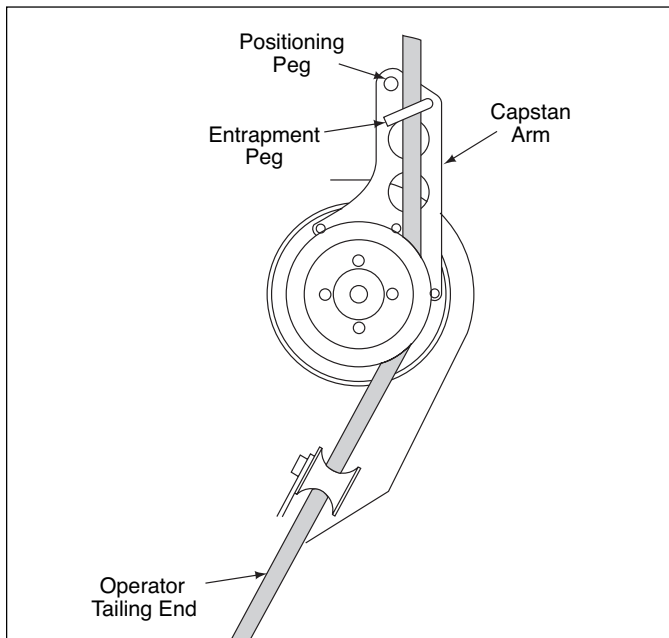

6. Check the ON/OFF switch on the puller to be sure it is OFF. Plug the puller into the receptacle of the standard force gauge. Plug the force gauge into an appropriate power supply (see Grounding Instructions in this manual).

Note: If using an extension cord, it must be rated for the current rating of the puller. Use the shortest cord possible. Longer cords reduce puller speed.

7. Position the force gauge so that it can be monitored by the puller operator.

Duty Cycle Table

Color Band on Meter	Pounds of Pulling Force	Alarm	Duty Cycle (in minutes)
Green	0-2500	off	continuous
Yellow	2500 - 3500	on	15 on / 15 off
Yellow	3500 - 4000	on	5 on / 15 off
Red	over 4000	on	puller will stop

8. Grasp the tailing end of the rope. Apply a slight amount of tailing force.
9. Turn the puller ON.
10. Tail the rope, allowing the spent rope to accumulate on the floor between the operator and the puller.
Note: The capstan arm is intended to pivot. Do not attempt to stop the arm from pivoting.
11. When the pull is complete, turn the puller OFF. Tie off the rope to the T-shaped cleat and anchor the cable.

Removing Cable

Removing old cable involves the same principles as installing new cable. However, there are some important differences.

Pulling Force

It is difficult to predict the amount of pulling force necessary to remove an old cable. The cable may be damaged, and it may break with an unexpectedly low pulling force.

The required pulling forces may be very high:

- The cable has probably “taken a set.” Unlike the new cable on a reel, cable in conduit has probably been in the conduit for years, or perhaps decades. The cable will resist bending and straightening as it is pulled through the conduit.
- The pulling lubricant has probably hardened, increasing pulling resistance.
- The insulation may be damaged and the cable may be corroded.
- Dirt or other foreign matter may have entered the conduit and may have cemented the cable in place.

Using a Force Gauge

When pulling old cable out of a conduit, the pulling force will be highest when *starting* the pull. Select a cable puller and pulling components to meet or exceed the estimated amount of pulling force necessary to remove the old cable. Because breaking the cable free will require the largest amount of pulling force, it is necessary to use a force gauge to prevent overloading the system components. For the 120-volt Tugger, use the 37171 Force Gauge. For the 220-volt Tugger, use the 05726 Force Gauge.

Carefully monitor the pulling force at the force gauge; if the puller is not able to begin the pull, shut off the puller and disassemble the setup. Start over with a puller and components of a higher force rating.

Puller Placement

Pulling out old cable is generally accomplished with the puller located some distance away from the end of the conduit. This allows the pulling crew to pull out a long section of cable before turning off the puller, cutting off the cable, and reattaching the grip(s). Mounting the cable puller a distance away from the end of the conduit increases the amount of exposed rope, which greatly increases the amount of violent whipping action which would occur if the rope or other components were to break.

To isolate the operator from the rope path:

- Locate the puller so that you will stand behind an obstruction, such as a wall. Set up the puller so that you will be able to maintain control of the pull. You need a clear view of the rope as it feeds onto the capstan, including several feet of the rope in front of the capstan. You must be able to turn off the puller before the pulling grip, connector, or swivel contacts the capstan.
- Use an additional pulling sheave to change the direction of the tailing rope. Anchor the sheaves so that you are close enough to maintain control of the pull. You need a clear view of the rope as it feeds onto the capstan, including several feet of the rope in front of the capstan. You must be able to turn off the puller before the pulling grip, connector, or swivel contacts the capstan.
Note: Use the additional pulling sheave to change the direction of the tailing rope (after the rope leaves the capstan). Do not change the direction of the pulling rope.
- Use a longer tailing rope than usual and stand away from the puller. Stand as far from the puller as possible, while maintaining control of the pull. You need a clear view of the rope as it feeds onto the capstan, including several feet of the rope in front of the capstan. You must be able to turn off the puller before the pulling grip, connector, or swivel contacts the capstan.

Dual Pulling

When the estimated amount of pulling resistance exceeds the ability of the puller, two pullers may be used to accomplish the pull. Connect the two pullers to the cables in parallel—use two sets of ropes, grips, and other accessories to avoid overloading any component of the pulling system.

Dual Pulling

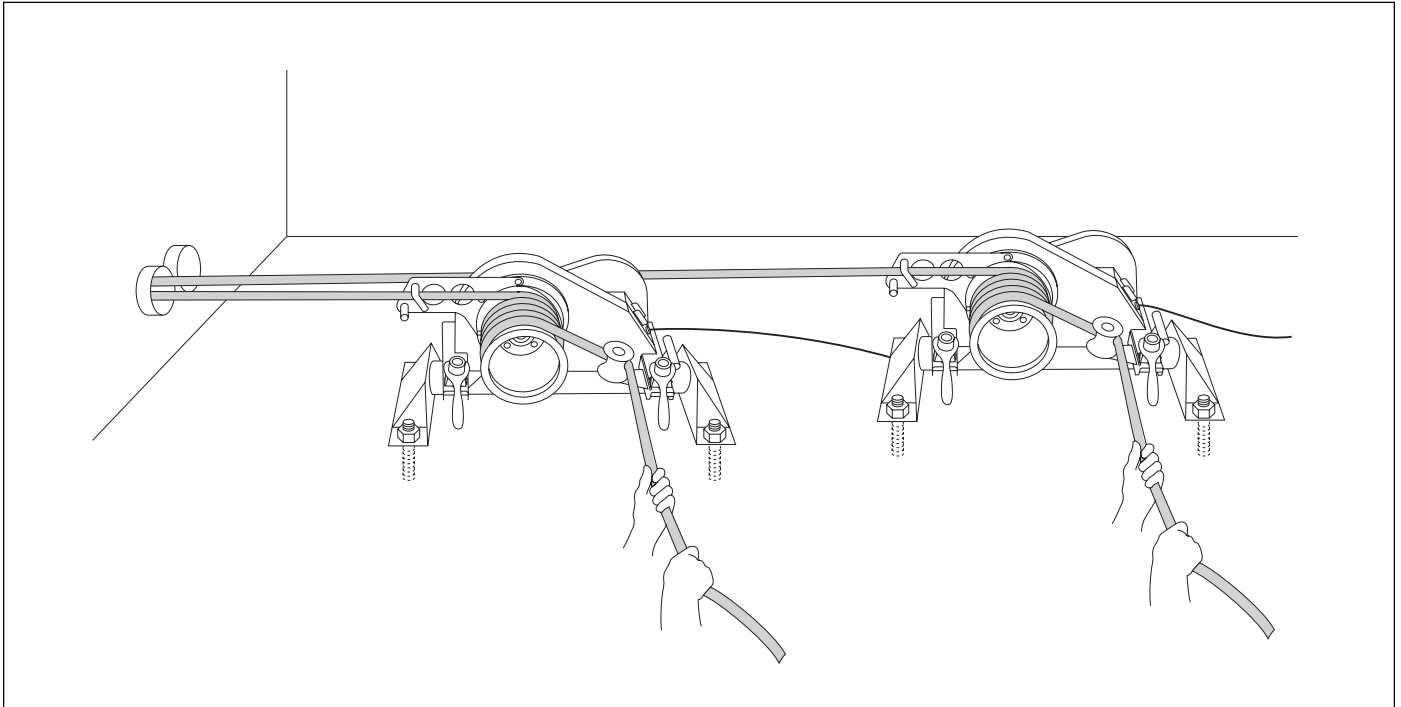

Maintenance

Read all instructions thoroughly. Be sure that you understand all of the instructions and have the necessary tools available before dismantling the puller.

Service Activity	Schedule
Lubricate the drive chains.	every 20 hours
Grease the drive chain shafts.	every 20 hours
Inspect the chains and ratchet pawl.	every 40 hours
Inspect the commutator brushes.	every 40 hours

Lubricating the Drive Chains (every 20 hours)

1. Remove the right guard (45) and left guard (3).
2. Lubricate the inside of the chains with 80W-90W gear oil.
3. Replace the guards and screws.

Greasing the Drivetrain Shafts (every 20 hours)

Apply a multipurpose NLGI Grade 2 grease (such as Mobilgrease® HP or Amoco Permalub) at the grease fittings (4 and 64). These fittings are located inside the capstan housing and under the countershaft (67).

	⚠ WARNING
	<p>Electric shock hazard: Disconnect the cable puller from the power supply before servicing. Failure to observe this warning could result in severe injury or death.</p>

Maintenance (cont'd)

Inspecting the Chains and Ratchet Pawl (every 40 hours)

1. Remove the right guard (45) and left guard (3).
2. Remove the connecting link (41) and #35 chain (40).
3. Remove the capstan retaining screws (2). Remove the lubricating screw (4) and washers (5-9). Remove capstan unit (10-19). Remove connecting link (21) and #50 chain (20).
4. Clean the chains thoroughly with solvent.
5. Lay the chains against a straightedge. Slide one end of the chain back and forth to check free play. See illustration below. If free play is more than 9mm (3/8"), replace the chain. Replace the chain if any links bind.

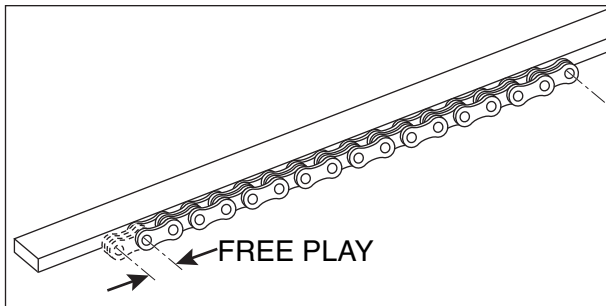

6. Lubricate the chains with 80W-90W gear oil.
7. Remove the ratchet pawl (70) and compression spring (69). Apply multipurpose NLGI Grade 2 grease (such a Mobilgrease® HP or Amoco Permalub) to all working surfaces. Replace the spring and pawl.
8. Assemble the #35 chain (40).
Note: Install the clip of each connecting link so that the closed end of the clip faces the direction of chain travel, as shown in the Exploded View.
9. Loosen, but do not remove, the four screws (38) that secure the motor. Push the motor away from the #35 sprocket (40) to put tension on the chain. Tighten the screws (38) to 8 Newton-meters (6 ft-lb).
10. Assemble in reverse order.
11. Plug the puller in and turn the puller ON. Listen for the clicking noise of the anti-reversing mechanism (ratchet pawl and compression spring). If you do not hear this clicking noise, inspect and repair the puller.

WARNING

Do not operate puller if the anti-reverse mechanism is not working.

Failure to observe this warning could result in severe injury or death.

Inspecting the Commutator Brushes (every 40 hours)

1. Remove two brush caps (101). Remove two brushes (102).
2. Measure the brushes. Replace both brushes if either brush is less than 9mm (3/8") long.

Maintenance (cont'd)

Replacing the Frame

	⚠ WARNING
	<p>Electric shock hazard: Disconnect the cable puller from the power supply before servicing. Failure to observe this warning could result in severe injury or death.</p>

Replace the frame if it appears damaged. During disassembly, inspect each part. Replace any worn, damaged, or missing parts with Greenlee replacement parts. Replace the needle bearings (61) regardless of their appearance.

1. Remove the left guard (3). Remove the lubricating screw (4), washers (5-9), and capstan unit (10-19).
2. Remove the #50 chain (20). Remove the sprocket (22) and washers (7).
3. Remove the right guard (45). Remove the #35 chain.
4. Remove the retaining ring (46), #50 sprocket (67), and all items located on the sprocket (39, 43, 44 and 60-64). Discard the needle bearings (61).
5. Remove the switch (52), horn (65), and related components.
6. Remove the motor, sheave, ratchet pawl and feet.
7. Assemble items to the new frame in reverse order.

Notes: Replace any components that show signs of wear or damage.

When replacing the items of the sprocket (67) assembly, install new needle bearings (61).

Install the clip of each connecting link so that the closed end of the clip faces the direction of chain travel, as shown in the Exploded View.

Troubleshooting the Electrical Circuit

	⚠ WARNING
	<p>Electric shock hazard: Disconnect the cable puller from the power supply before servicing. Failure to observe this warning could result in severe injury or death.</p>

See the wiring diagram. Use a continuity checker to check the electrical circuit. Lack of continuity in the following procedure indicates that a repair is necessary.

1. Unplug the puller.
2. Set the switches to ON.
3. Place the probes of the continuity checker across the following terminals of the cable puller and force gauge. All of these pairs of terminals should have continuity.

To check the switch:

- A and B
- C and D (220-volt models only)

To check the connectors:

- E and A
- F and K
- G and H

To check the motor:

- J and K

If the motor fails this check, inspect the motor components (brushes, armature, and wires). Replace any parts that are worn or damaged. Replace both brushes if either brush measures less than 9mm (3/8") long.

Troubleshooting

Should the puller become inoperative, refer to the troubleshooting table below. While performing any repairs, inspect the motor, capstan, and drivetrain.

Problem	Probable Cause	Probable Remedy
Motor will not run.	<p>No power at supply circuit.</p> <p>Faulty switch or wiring.</p> <p>Motor faulty.</p>	<p>Check power supply with a voltmeter. See the Specifications section of this manual.</p> <p>Check the switch and wiring for continuity.</p> <p>Check the motor and wiring for continuity. Check condition of brushes. Replace any worn or damaged items.</p> <p>Replace motor</p>
Capstan does not rotate while motor is running.	<p>#50 chain broken.</p> <p>#35 chain broken.</p> <p>Broken sprocket in gearbox or stripped shaft in motor.</p>	<p>Replace #50 chain.</p> <p>Replace #35 chain.</p> <p>Disassemble puller. See disassembly instructions under Inspecting the Chains and Ratchet Pawl. Replace any worn or damaged drive components.</p>

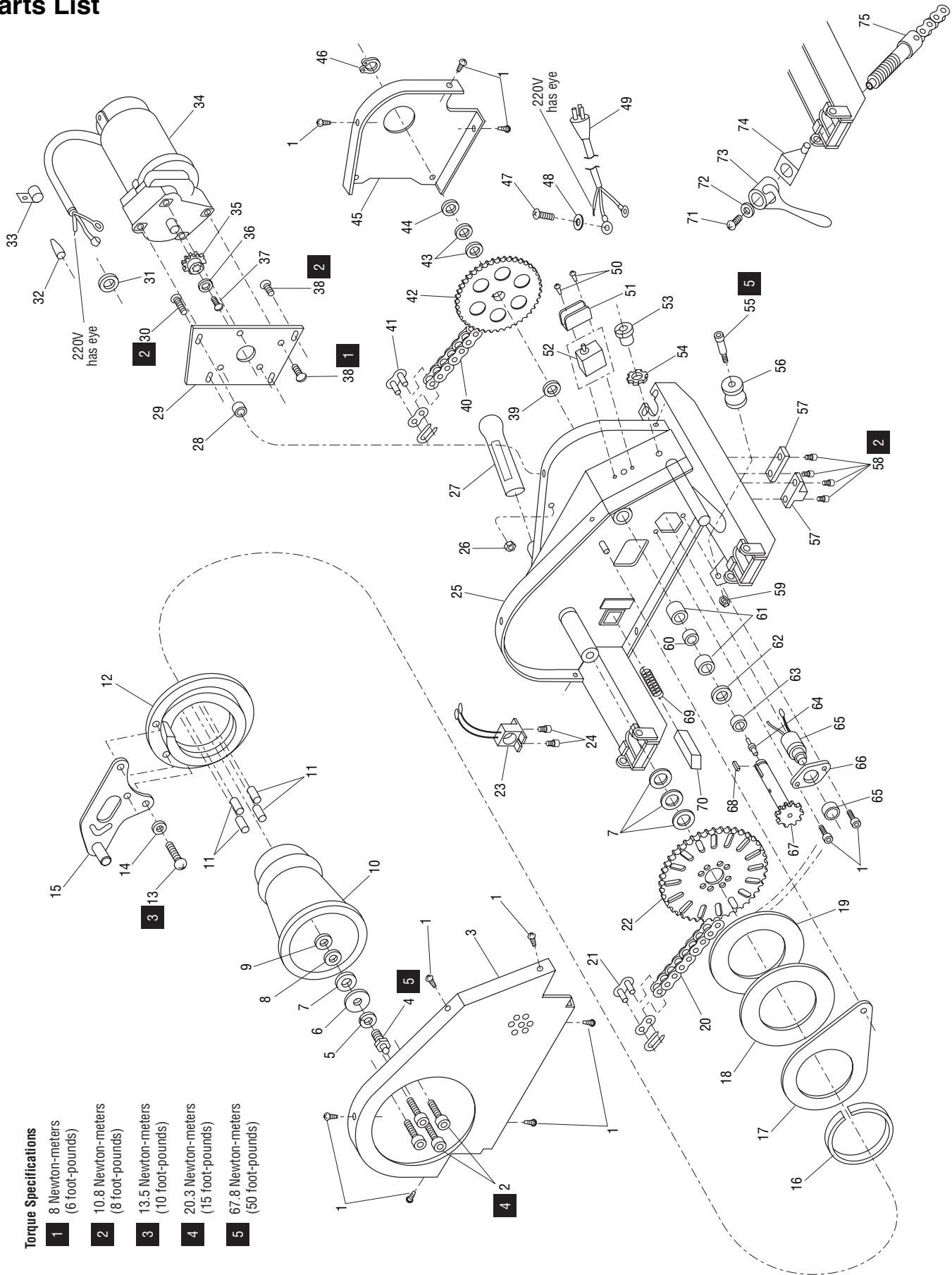
Parts List

Parts List (cont'd)

Key	Part No.	Description	Qty
□1	90531949	Screw, self-tapping, #10 –16 x .250, □Phillips head.....	11
□2	90539222	Screw, cap, 3/8 – 16 x 2.75 skt head	4
□3	50353020	Guard, left.....	1
□4	50255215	Screw unit, lubricating	1
□5	90516036	Washer, lock, .643 x 1.08 x .156 spring	1
□6	50299387	Washer, flat, .687 x 2.00 x .125	1
□7	50258966	Washer, flat, 1.28 x 1.75 x .125 fiber	4
□8	90526449	Washer, flat, .625 x 1.00 x .031	1
□9	90526457	Washer, flat, .625 x 1.00 x .062	1
10	50355414	Capstan unit	1
11	90501349	Pin, dowel, .375 x 2.00	4
12	50352911	Ramp	1
13	90525876	Screw, cap, 5/16 –18 x .875, □socket button head.....	3
14	90516028	Washer, lock, .323 x .586 x .078 spring	3
15	50353055	Arm, capstan	1
16	50353225	Bearing, ramp	1
17	50353187	Plate unit, anti-rotation	1
18	50353101	Washer, flat, 4.80 x 8.00 x .060 thrust	1
19	50353209	Washer, flat, 4.80 x 8.00 x .060 backing	1
20	50353446	Chain, roller, #50	1
21	90531957	Master link for #50 chain	1
22	50352946	Sprocket, #50, 48 teeth	1
23	50354302	Current transformer unit (120-volt model)	1
	50357670	Current transformer unit (220-volt model)	1
24	90539311	Screw, self-tapping, #10 x .500	2
25	50352920	Frame unit, puller	1
26	90516699	Nut, hex 1/4 – 20	1
27	50232584	Grip, rubber, .600 x 1.00 x 4.50	1
28	50353233	Spacer, .284 x .440 x .75	1
29	50352962	Plate, motor mounting	1
30	90539206	Screw, cap, 1/4 – 20 x 1.37, □socket button head.....	1
31	90541243	Bushing, strain relief.....	2
32	91864852	Connector, wire, twist-o□(120-volt model only).....	1
33	90539567	Clamp, cushioned support.....	1
34	50354353	Motor, electric (120-volt).....	1
	50357646	Motor, electric (220-volt).....	1
35	50353136	Sprocket, #35, 12 teeth	1
36	90533186	Washer, flat, .211 x .625 x .047	1
37	90527917	Screw, cap, #10 – 32 x .375 button	1
38	90516672	Screw, cap, 1/4□– 20 x .625, button socket.....	7
39	50179160	Washer, flat, 1.00 x 1.50 x .031 fiber	2
40	50353454	Chain, roller, #35	1
41	90537300	Master link for #35 chain	1

Parts List (cont'd)

Key	Part No.	Description	Qty
42	50352954	Sprocket, #35, 60 teeth	1
43	90539192	Washer, shim, 1.00 x 1.50 x .062	3
44	90539184	Washer, shim, 1.00 x 1.50 x .032	1
45	50353012	Guard, right	1
46	90513010	Retaining ring, .987, Truarc # 5160-98	1
47	90514602	Screw, self-tapping, #10 – 32 x .375 Phillips (120-volt model only) ..	1
48	90507509	Washer, lock, .200 x .373 x .023 (120-volt model only)	1
49	50371703	Power cord (120-volt model)	1
	50057251	Power cord (220-volt model)	1
50	90522036	Screw, machine, #6 – 32 x .250	2
51	50297082	Guard, switch	1
52	91863880	Circuit breaker (120-volt model)	1
	91868017	Circuit breaker (220-volt model)	1
53	90541243	Bushing, strain relief	1
54	91862639	Nut, lock	1
55	90539214	Screw, shoulder, .620 x 1.75 x 1/2 – 13	1
56	50353110	Sheave	1
57	50296647	Foot	4
58	90505794	Screw, cap, 1/4 – 20 x .500 socket head	8
59	90527941	Nut, hex 1/2 – 13	1
60	50179047	Spacer, 1.06 x 1.19 x .560	1
61	90514599	Needle bearing, 1.00 x 1.31 x 1.00	2
62	50353349	Washer, flat, 1.01 x 1.75 x .062 thrust	1
63	50353330	Spacer, 1.01 x 1.19 x .312	1
64	90512715	Grease fitting	1
65	50354310	Horn (120-volt model)	1
	50359169	Horn (220-volt model)	1
66	50354337	Bracket, horn mounting	1
67	50353128	Countershaft	1
68	50256173	Key, square, .250 x .760,	1
69	50163094	Spring, comp, .210 x .300 x 1.62	1
70	50301020	Pawl, ratchet	1
71*	90539656	Screw, cap, 1/4 – 20 x .500 Torx button	2
72*	50356577	Washer, flat, .253 x .725 x .070	2
73*	50296302	Handle unit, vise chain	2
74*	50356607	Positioner unit, chain	2
75*	50356615	Screw unit, 36" vise chain	2
Kit			
*	50296310	Chain unit (includes one each of the items marked with an asterisk)	2

Decals For The Tugger

50356623	Decal, read IM (120-volt model)
50358995	Decal, read IM (220-volt model)
99935767	Decal, technical assistance
50353292	Decal, rope ramp
50299360	Decal, capstan rotation

Exploded View

Gear-Motor Unit

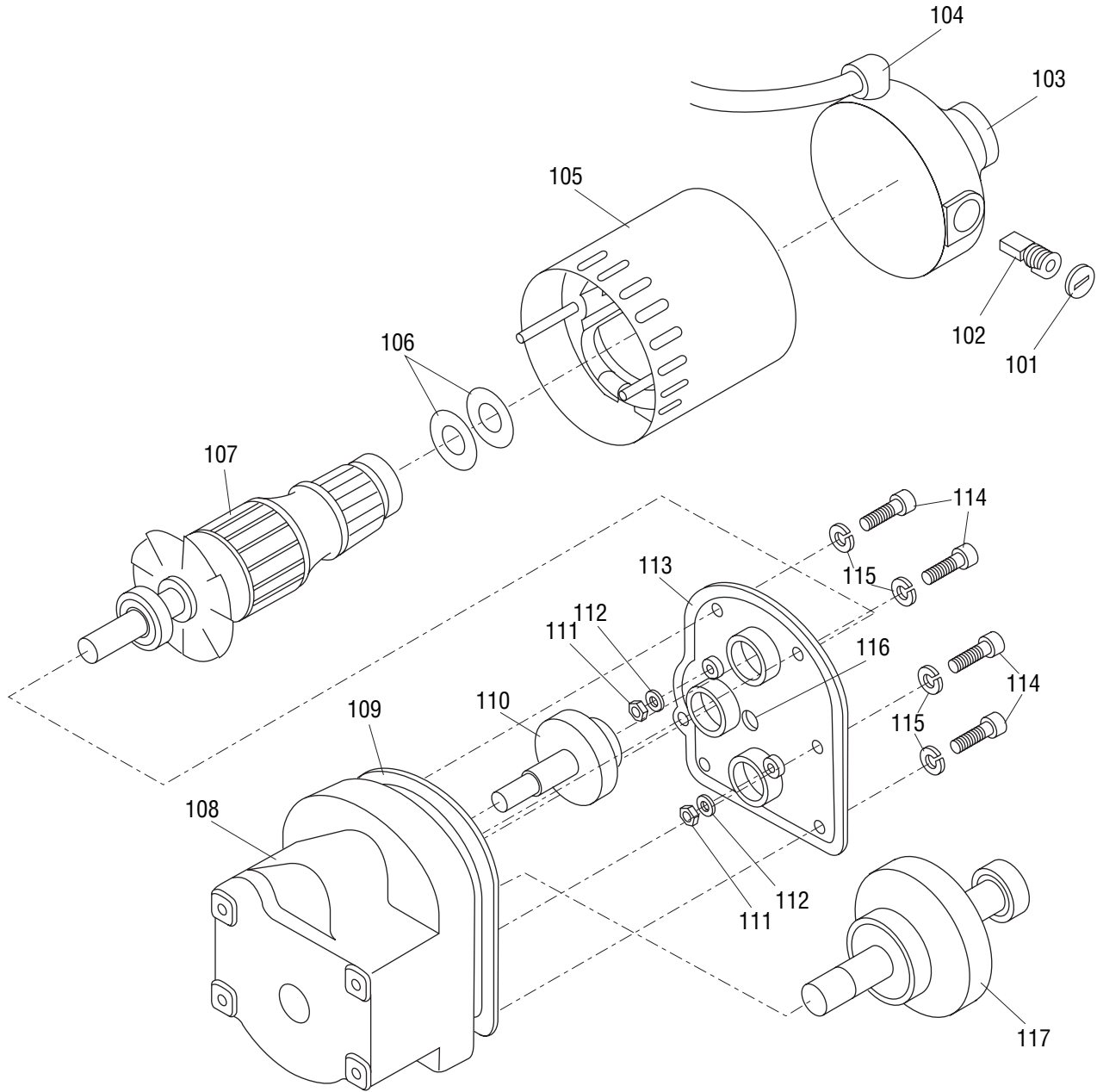

Parts List

Motor and Gearbox (120-Volt and 220-Volt Models)

Key	Part No.	Description	Qty
101	91861136	Brush cap	2
102	91861098	Brush	2
103	91864020	End cap assembly	1
104	90541243	Bushing, strain relief	1
105	91863953	Field assembly (120-volt model)	1
	91864356	Field assembly (220-volt model)	1
106	90533232	Washer, Belleville 10mm	2
107	91864011	Armature assembly (120-volt model)	1
	91864364	Armature assembly (220-volt model)	1
108	91863988	Gearhousing assembly	1
109	91861829	Gasket	1
110	91863970	First gear assembly	1
111	90516869	Nut, hex, #10 – 32 full	4
112	90507509	Washer, lock, #10 internal tooth	4
113	91863961	Gearhousing cover	1
114	90508688	Screw, cap, 1/4 – 28 x 1.00 skt head	6
115	90516745	Washer, lock, 1/4" internal tooth	6
116	91863996	Armature shaft seal	1
117	91864003	Output gear assembly	1

Exploded View

50371711 — Force Gauge Unit with Serial Code ZZ (120-Volt Models)

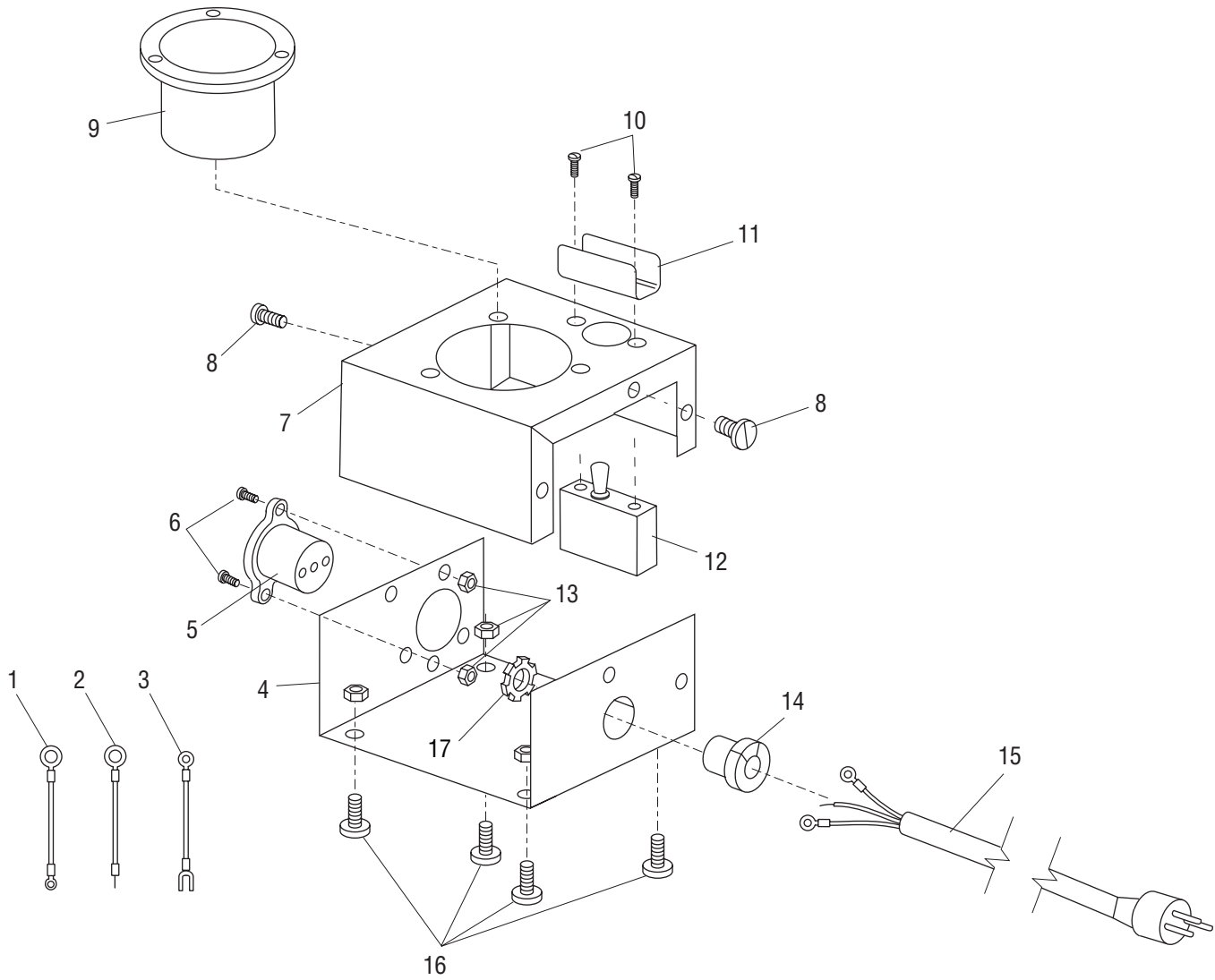

Parts List

50371711 – Force Gauge Unit with Serial Code ZZ (120-Volt Models)

Key	Part No.	Description	Qty
	50371711	Force gauge unit	
1	50371622	Wire, 12 AWG x 3.00, black	1
2	50371630	Wire, 12 AWG x 7.00, black	1
3	50371649	Wire, 12 AWG x 4.00, green	1
4	50371088	Box	1
5	91866847	Receptacle, female	1
6	90514408	Screw, machine, #8–32 x .375 round head	2
7	50371070	Cover	1
8	90531949	Screw, self-tapping, #10– 16 x .250 Phillips head	6
9	50353675	Meter (supplied with hardware)	1
10	90522036	Screw, machine, #6–32 x .250 round head	2
11	50297082	Guard, switch	1
12	91863830	Switch, toggle, 120-volt, single-pole (supplied with hardware)	1
13	90506332	Nut, hex, #8–32	4
14	90541243	Bushing, strain relief	1
15	50371703	Cord, power, 12 AWG x 6'	1
16	90539346	Bumper, #8–32 machine screw, rubber	4
17	91862639	Nut, lock, 1/2" conduit	1

Decals for the Force Gauge:

50303929	Decal, damp warning
50327186	Decal, adjustment zero
50356674	Decal, identification (120-volt model)

Exploded View

50057260—Force Gauge Unit with Serial Code ACP (220-Volt Models)

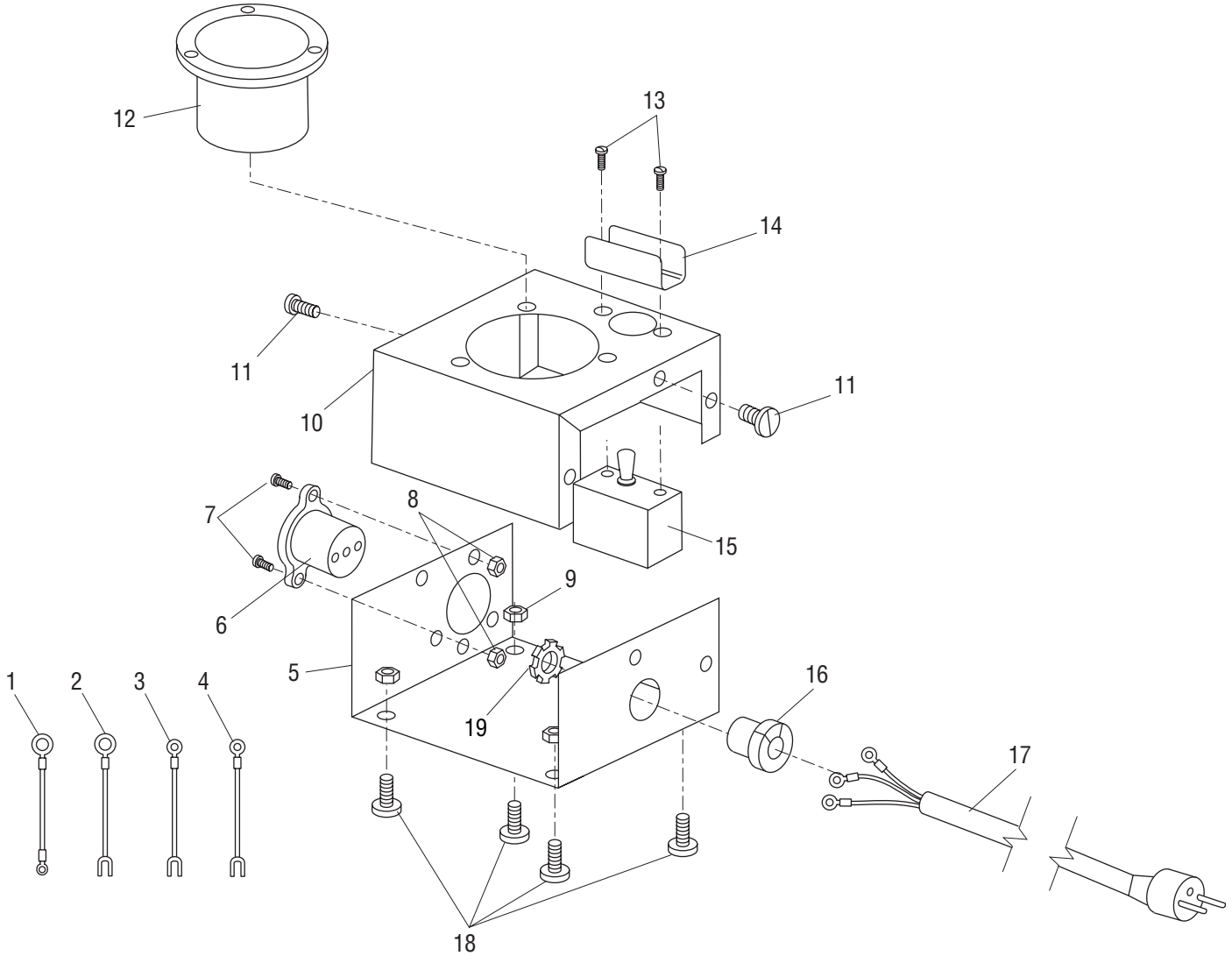

Parts List

50057260—Force Gauge Unit with Serial Code ACP (220-Volt Models)

Key	Part No.	Description	Qty
	50057260	Force gauge unit	
1	50314807	Wire, 14 AWG x 3.00, brown	1
2	50356313	Wire, 14 AWG x 6.00, brown	1
3	50314785	Wire, 14 AWG x 5.00, green with yellow stripe	1
4	50356321	Wire, 14 AWG x 6.00, blue	1
5	50054872	Box, lower	1
6	91869129	Receptacle, remale	1
7	90502787	Screw, cap, #6–32 x .500 socket head	2
8	90506324	Nut, hex, #6–32	2
9	90506332	Nut, hex, #8–32	4
10	50371070	Box, upper	1
11	90531949	Screw, self-tapping, #10–16 x .250 Phillips head	6
12	50357689	Meter (supplied with hardware)	1
13	90522036	Screw, machine, #6–32 x .250 round head	2
14	50297082	Guard, switch	1
15	91864135	Switch, toggle, 220 V, DPDT	1
16	90541243	Bushing, strain relief	1
17	50079379	Cord, power, 14 AWG x 6.5' (198 cm)	1
18	90539346	Bumper, #8–32 machine screw, rubber	4
19	91862639	Nut, lock, 1/2" conduit	1

Decals for the Force Gauges:

50303929	Decal, damp warning
50327186	Decal, adjustment zero
50057243	Decal, identification (220-volt model)

Wiring Diagram

Tugger

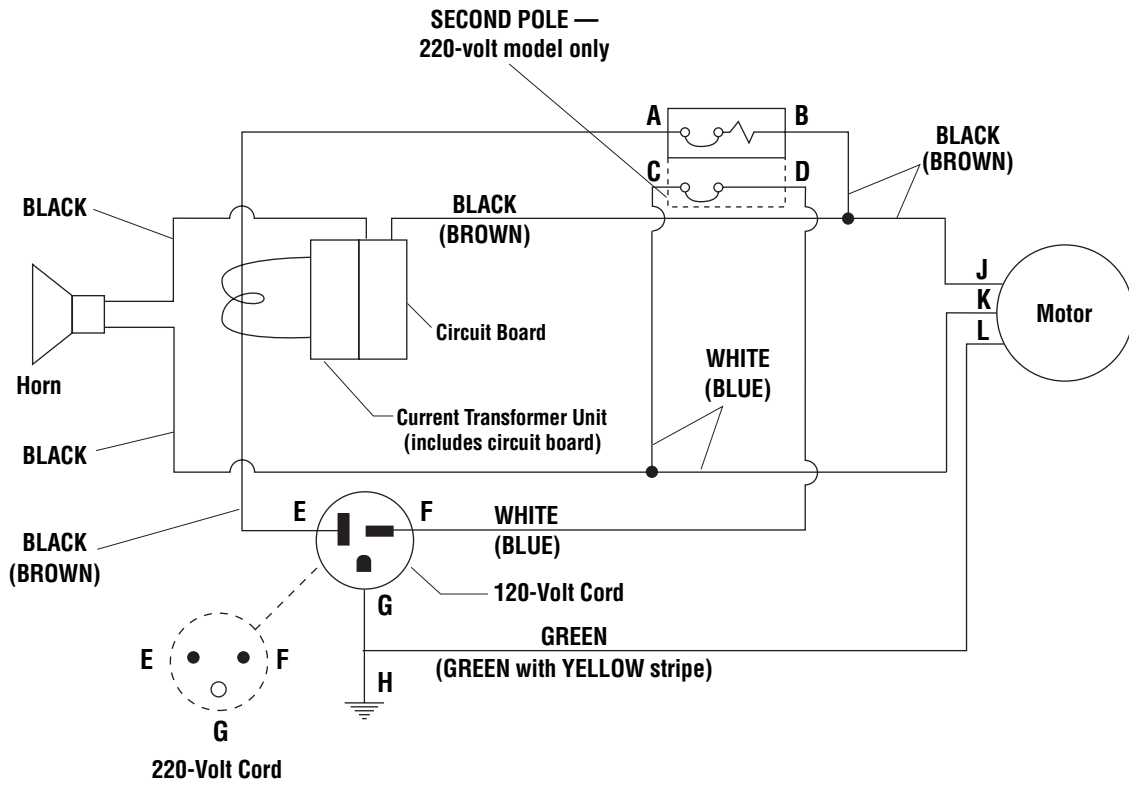

Wiring Diagram

Force Gauge, 120-Volt Model (50371711)

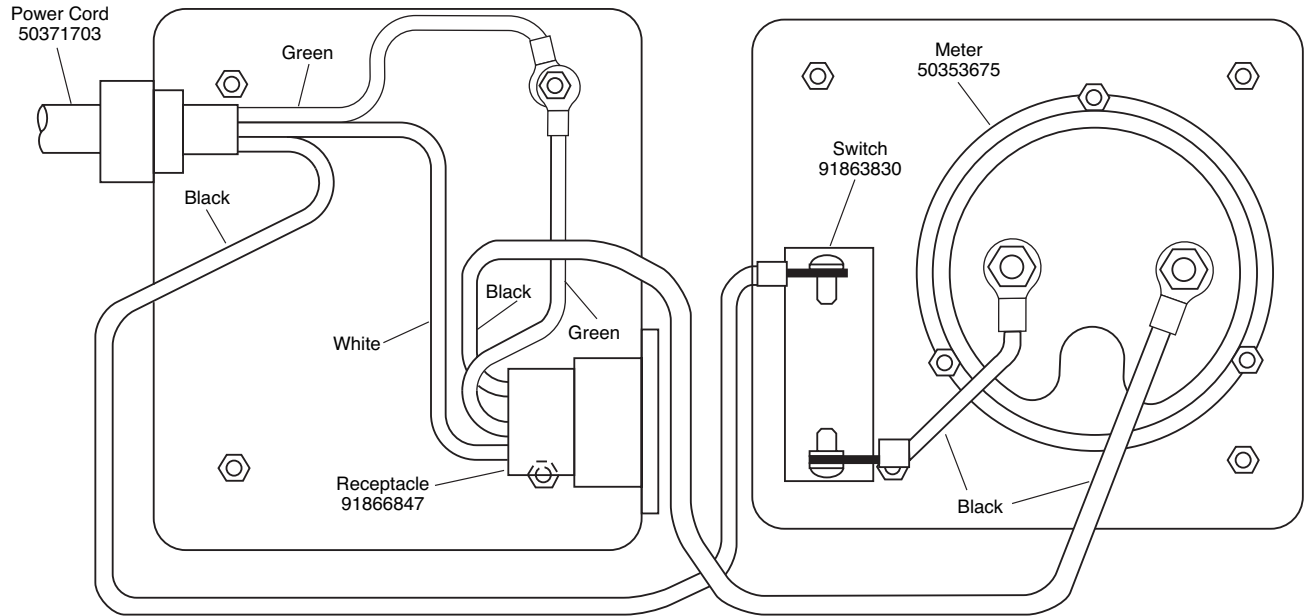

Force Gauge, 220-Volt Models (05726)

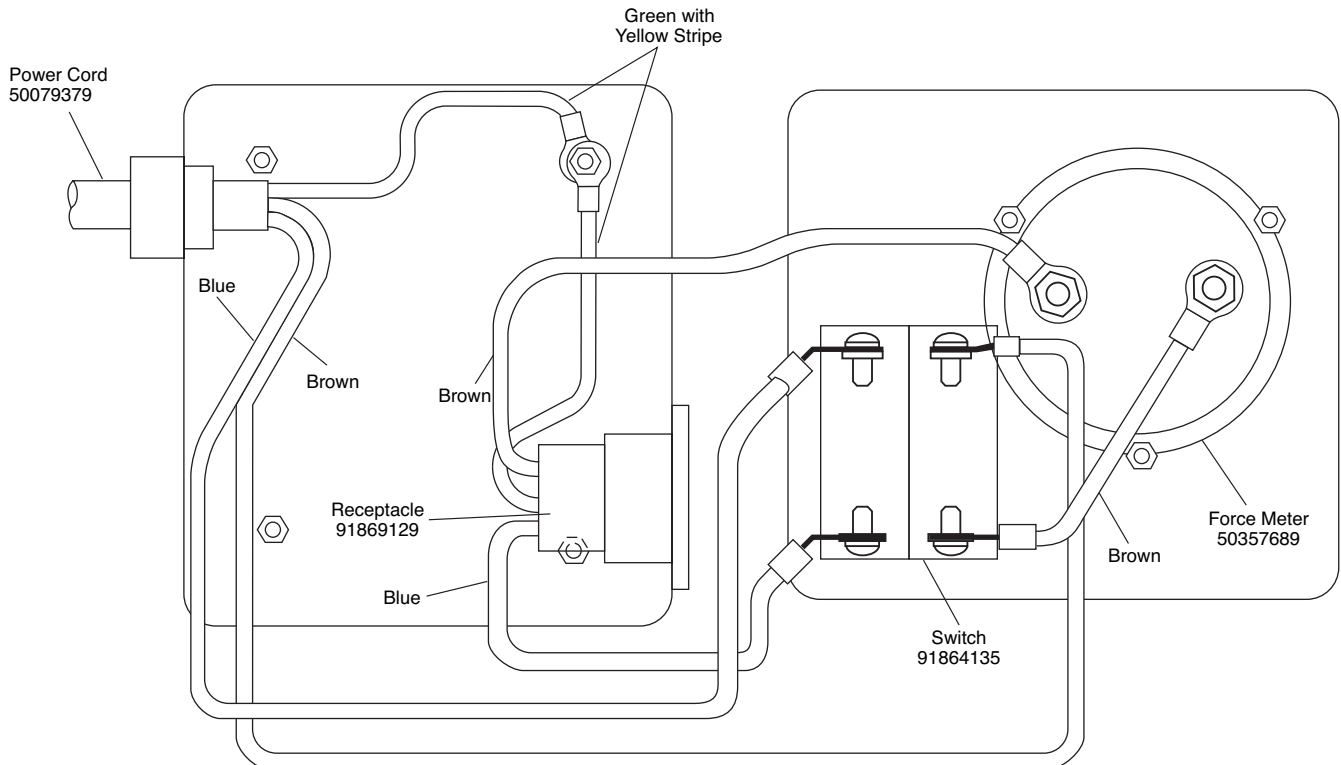



GREENLEE®

A Textron Company

USA	800-435-0786	Fax: 800-451-2632
	815-397-7070	Fax: 815-397-1865
Canada	800-435-0786	Fax: 800-524-2853
International	+1-815-397-7070	Fax: +1-815-397-9247

4455 Boeing Drive • Rockford, IL 61109-2988 • USA • 815-397-7070
An ISO 9001 Company • Greenlee Textron Inc. is a subsidiary of Textron Inc.

www.greenlee.com

Printed in USA