



www.icmcorp.net

CABLE SERIES: RGB

TOOL: CPLCCT-SLM

TIP: SILVER OR GOLD

STRIPPER: PS59/6/RGB

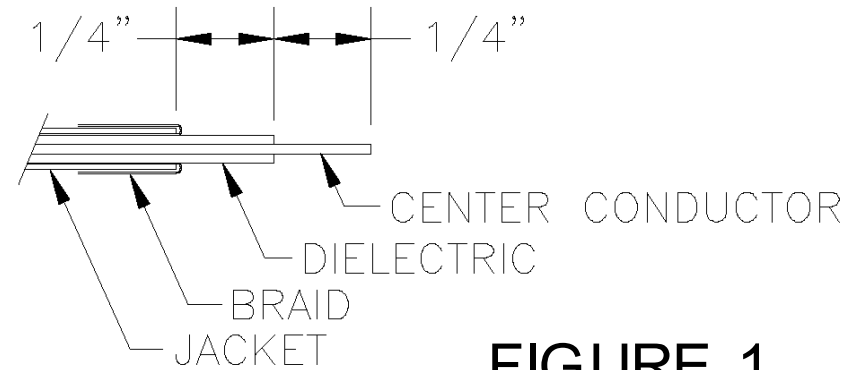

FIGURE 1

F-CONN RCA FOR RGB

- 1) A. Before prepping the cable, cut the cable at a right angle to the jacket.
- B. Expose 1/4" center conductor and 1/4" dielectric as shown in Figure 1.

Use Strip Tool PS59/6/RGB or —

For the 1 RGB (orange connector) strip the center conductor to 18 AWG and the dielectric to 14 AWG using a wire stripping tool.

For the 1.5 RGB (purple connector) strip the center conductor to 14 AWG and the dielectric to 10 AWG using a wire stripping tool.

2) Insert the plastic guide onto the center conductor as shown

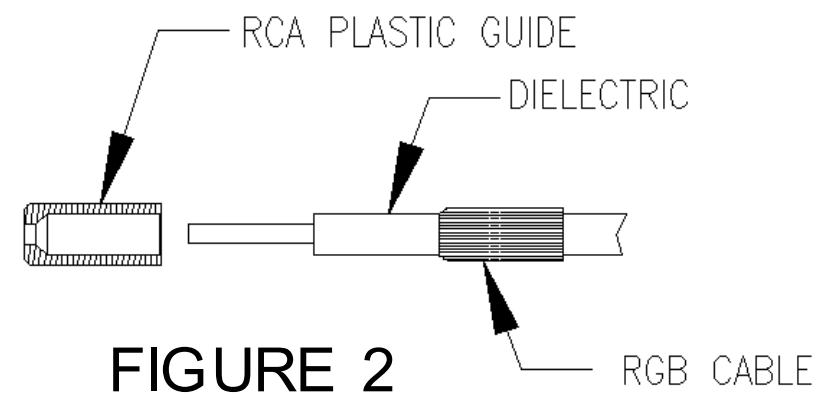
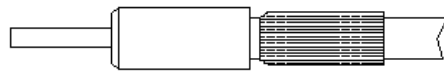

FIGURE 2

3) Insert the sleeve over the plastic guide until it covers the braid that was folded over during initial preparation as shown in figure 3.

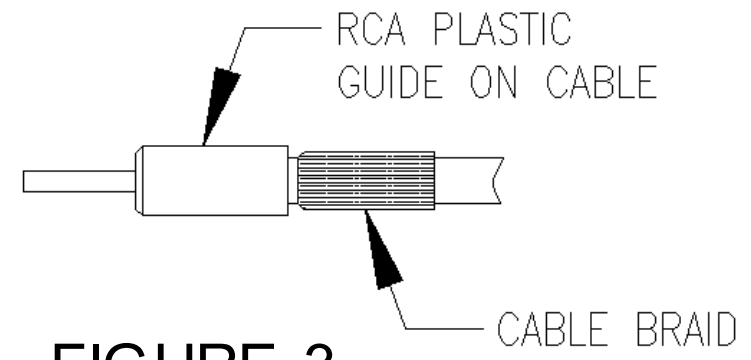
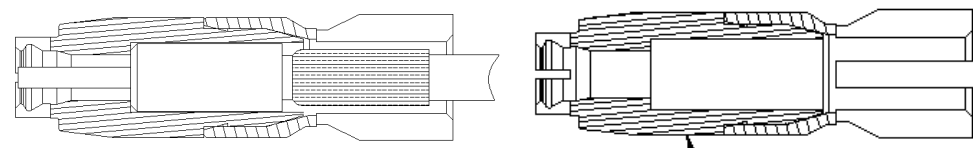

FIGURE 3

4) Holding the cable with sleeve & plastic guide firmly, insert the tip as shown in figure 4

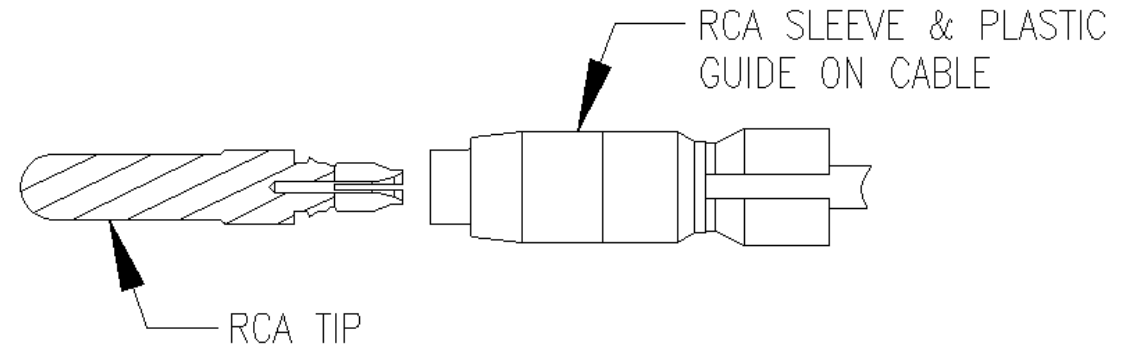
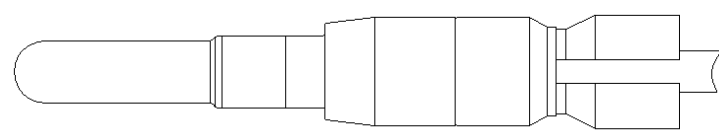

FIGURE 4

5) Insert the assembled cable with sleeve into the connector housing as shown in figure 5.

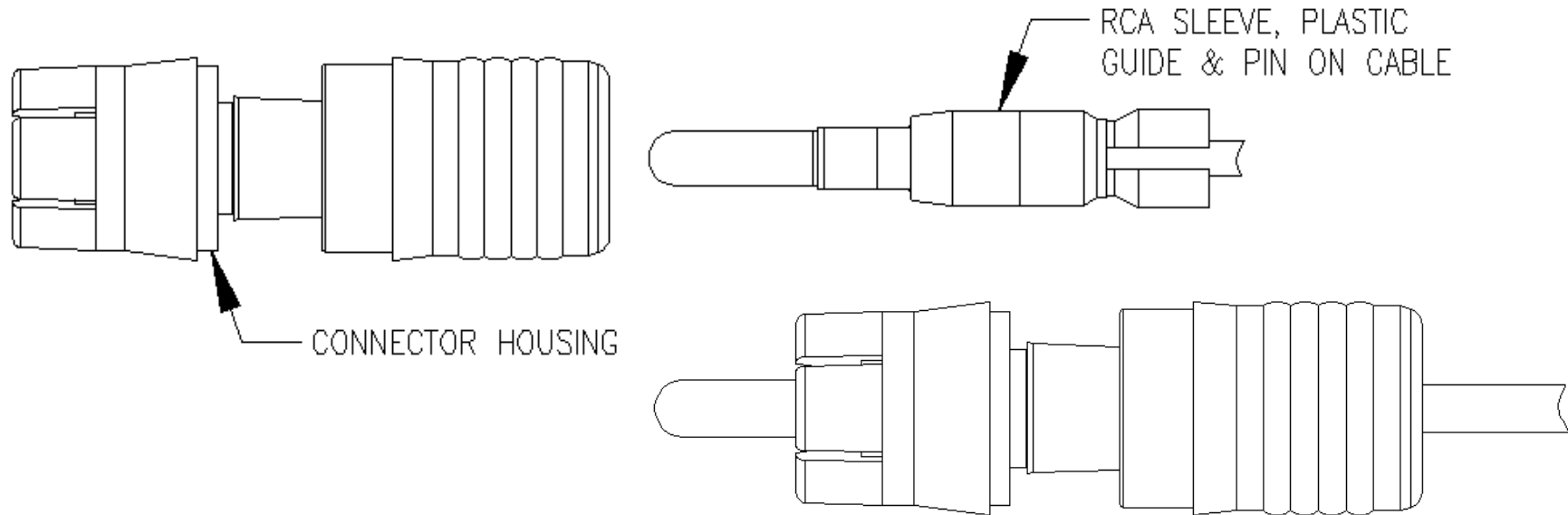

FIGURE 5

6) Crimp the connector as shown in figure 6.

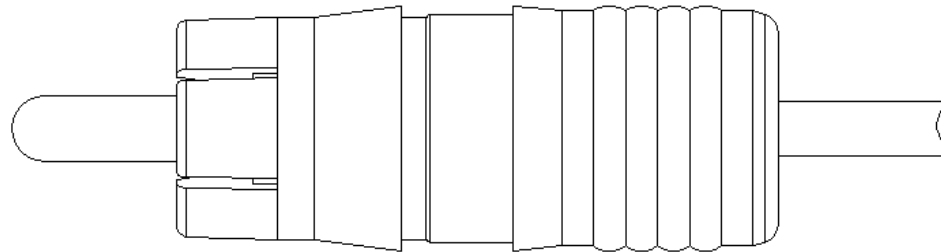

FIGURE 6

7) Install the color ring onto the connector as shown in figure 7.

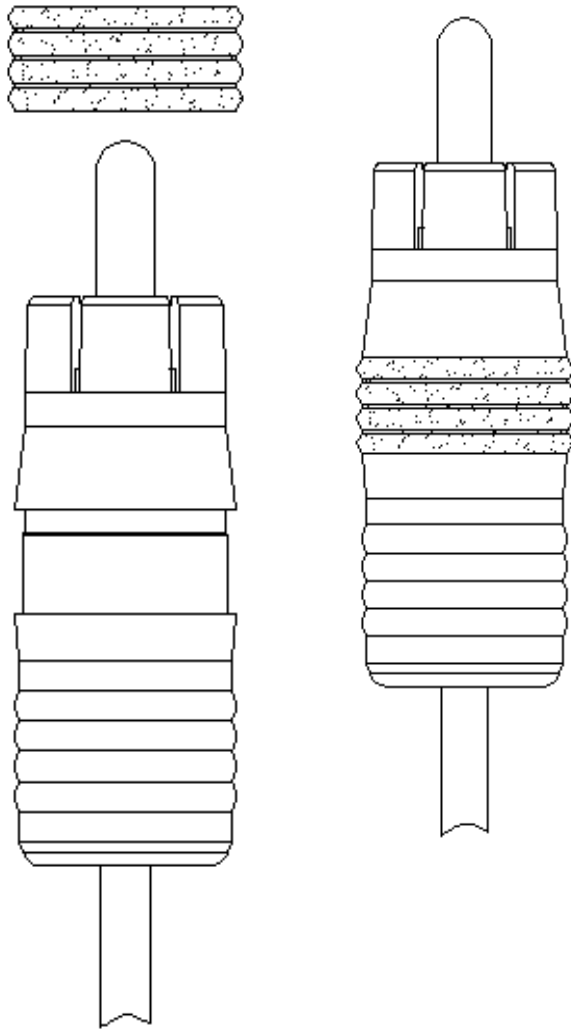

FIGURE 7

CPLCCT-SLM Tool Instructions

Insert the appropriate tip into the BNC spring clip before inserting the RCA connector. Insert the tip so that the slot opening faces up. The tip can be stored on the bottom of the tool by screwing it in place on the underside of the body.

Grasp the body of the tool with your fingers and start to close the handle of the tool. As the handle closes, the plunger slides towards the yoke. When the handle is completely closed against the body, the connector has been terminated.

