

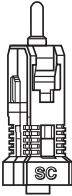





SC Thread-Lock® Connector Assembly Instructions

SC Thread-Lock Singlemode Connector	49884-SSC
SC Thread-Lock Multimode Connector	49884-MSC
Universal Fiber Optic Tool Kit	49800-UTK
Universal Fiber Optic Tool Kit Plus with Thread-Lock Versa-Cleave™	49800-UTP
Universal Fiber Optic Consumable Kit	49800-CON
ST/SC Combination Tightening Tool	49886-CTT
SC Duplex Clip	49884-DPC
Thread-Lock Versa-Cleave	49886-TVC

COMPONENT PARTS INCLUDED INSIDE THE POLYBAG

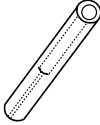
		
<p>1 SC Thread-Lock Connector with Dust Cap</p>	<p>1 Each 900µm Buffered Fiber Protective Boot</p>	<p>1 Each Jacketed Fiber Protective Boot</p>

			
<p>1 Each Short 900µm Build-up Sleeve (BUS) (5/16" Long)</p>	<p>1 Each Long 900µm Build-up Sleeve (BUS) (5/8" Long)</p>	<p>1 Each 250µm Build-up Sleeve (BUS) (15/16" Long)</p>	<p>2 Each Retention Sleeve</p>

NOTE: 3 Build-up Sleeves sold separately as Leviton PN# 49885-SBS.

NOTE: The Thread-Lock Connector is a mechanical connector, designed specifically for indoor applications and to meet TIA-568-B.3 requirements. Use of this product in non-standard environments will void the warranty.

A. 2.0MM, 2.5MM & 3.0MM JACKETED CABLE

1. Place 3mm jacketed fiber protective boot on cable and slide back. (Figure 1)

NOTE: Distances in all drawings are not to scale.

NOTE: To help avoid tool, buffer and fiber contamination, clean 4-6 inches of jacket first with a 99% alcohol wipe, then with a lint-free wipe.

2. Remove 1 1/2" of jacket. Strip the 900µm buffer back 1". Clean with a 99% alcohol wipe followed by a lint-free wipe to remove any contaminants. Strip about 1/4" at a time (Figure 2). Gently snap the shorter (5/16") length 900µm Build-up Sleeve (BUS) onto the 900µm buffered fiber, butting it up against the jacket.

3. Trim aramid strands back even with the end of the BUS (approximately 1/4"). (Figure 3)

4. Distribute aramid strands evenly over the outer surface of the 900µm BUS. Fold the retention sleeve over the BUS and the distributed aramid strands. Align end of the BUS with threaded end of the retention sleeve. Leave 1/4" of buffered fiber exposed and complete assembly and polishing process as described in section D. (Figure 4)

Refer to Assembly and Polishing Process, Page 5, Section D.

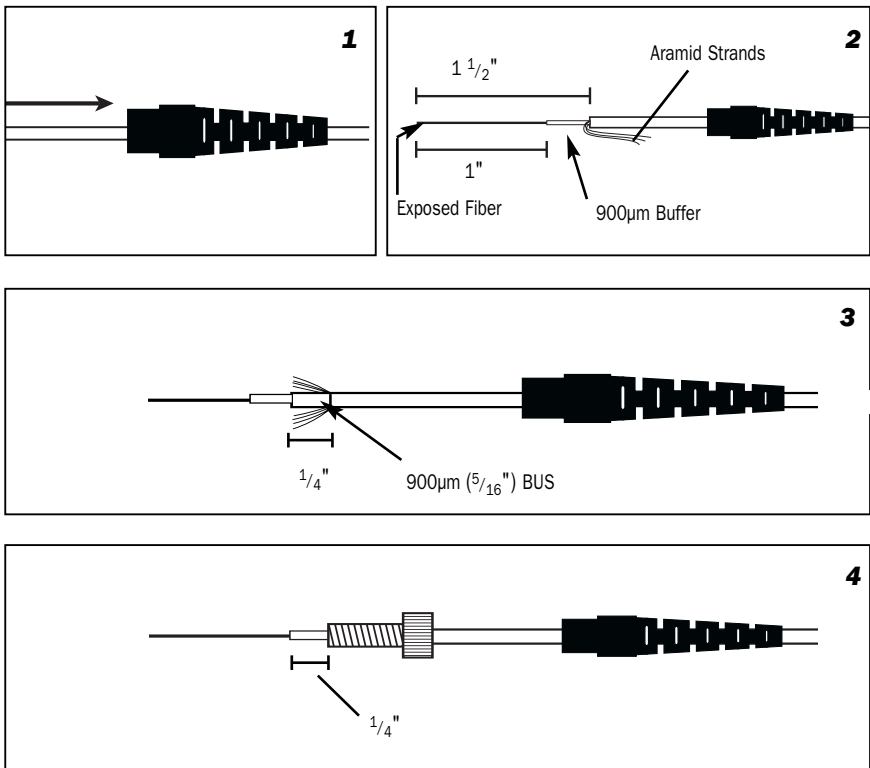

B. 900µm BUFFERED FIBER

1. Place 900µm buffered fiber protective boot on cable and slide back. (Figure 5)

NOTE: To help avoid tool, buffer and fiber contamination, clean 4-6 inches of jacket first with a 99% alcohol wipe, then with a lint-free wipe.

2. With indelible marker, mark the buffer 1" and 1 1/4" from the end of the 900µm tight buffer. (Figure 5)

NOTE: Use a ruler, such as the one located on Leviton's red handled, 900µm Buffer Remover (PN# 49886-BR9) to mark the measurements on the buffer.

3. Using red handled buffer remover, strip and remove buffer in four 1/4" increments, until the fiber is stripped back to first mark (1") on the buffer. (Figure 6)
4. Clean exposed fiber and at least 1" of 900µm jacketing with 99% isopropyl alcohol and wipe with lint-free wipe to remove any debris. When cleaning, pull on fiber gently, but with firm pressure; this tests for damaged fiber.
5. Line up the longer (5/8"), 900µm BUS behind the second mark (at 1 1/4") from the end of the fiber. Then snap it into place. (Figure 7)
6. Fold threaded retention sleeve over BUS flush with the end, then complete the assembly and polishing process as described in Section D. (Figure 8)

Refer to Assembly and Polishing Process, Page 5, Section D.

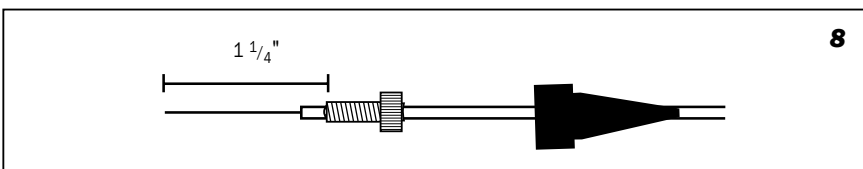
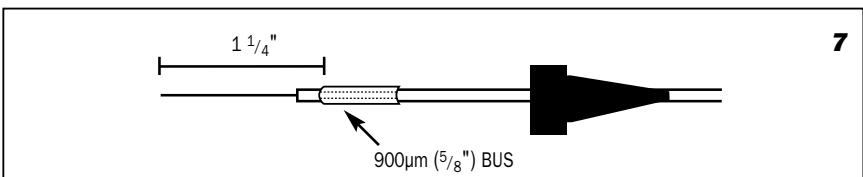
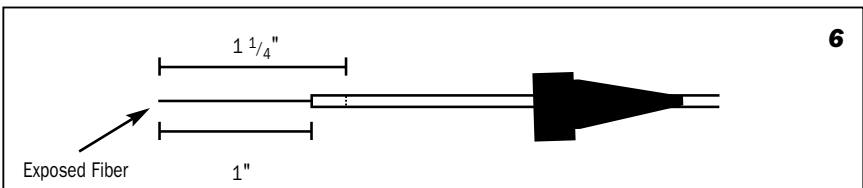
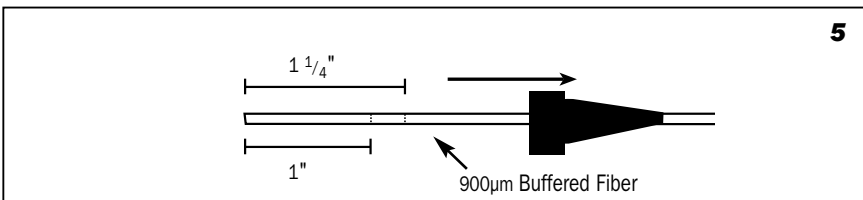

C. 250 μ m LOOSE TUBE GEL FILLED FIBER

1. Remove all gel from fiber with industrial strength cleaning pad such as a "D-Gel™" pad. Once the gel compound is completely removed, repeat the process using a 99% isopropyl alcohol. **(Figure 9)**
2. Install 900 μ m fan-out kit per manufacturer's instructions and place bare fiber protective boot on assembly and slide back. Ensure at least 2" of 250 μ m coated fiber protrudes from the end of the tubing. **(Figure 10)**. Clean 3-4 inches of buffer and fan-out kit with 99% isopropyl alcohol.
3. Feed the 250 μ m fiber into the 250 μ m ($15/16$ ") BUS until 900 μ m tubing is fully seated into the back of the BUS, approximately $1/2$ ". **(Figure 11)**
4. Grasp the BUS firmly, and strip fiber coating back about 1", leaving $1/4$ " of 250 μ m coating exposed **(Figure 12)**. Clean exposed fiber with 99% isopropyl alcohol wipes.
5. Fold retention sleeve over BUS so it is even with the end **(Figure 13)**. Complete the assembly and polishing process as described on Page 5, Section D.

Refer to Assembly and Polishing Process, Page 5, Section D.

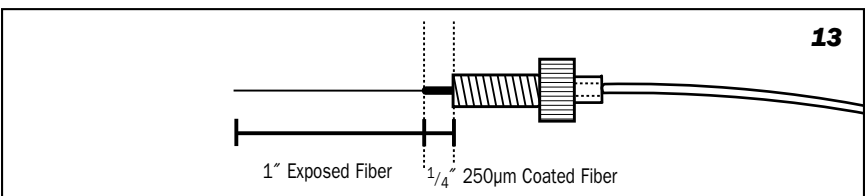
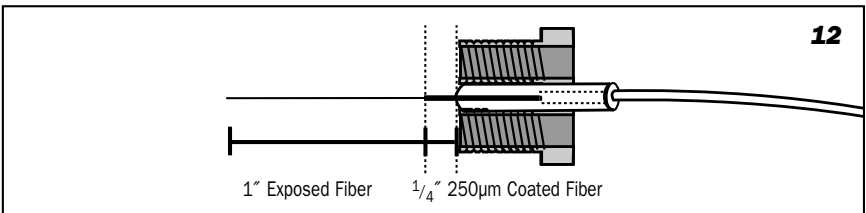
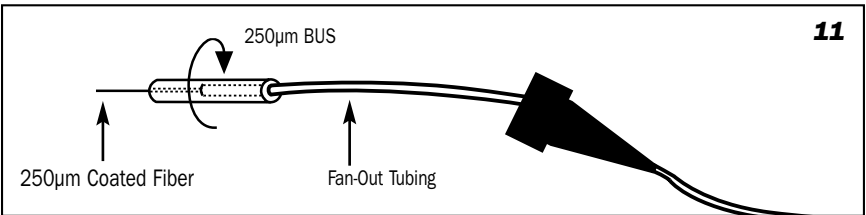
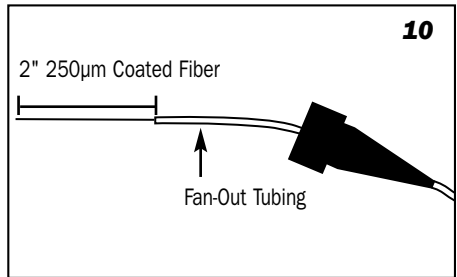
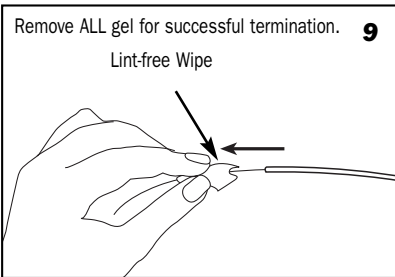

D. ASSEMBLY AND POLISHING PROCESS

1. Remove dust cap, then insert connector into tightening tool. While firmly holding the threaded sleeve around the fiber, insert the first few threads of the sleeve evenly into connector housing. (**Figure 14**). Rotate connector housing down over threaded sleeve. To rotate, use the tightening tool and grip the sleeve head with pliers. Rotate connector housing, not threaded sleeve (**Figure 15**). If necessary, trim away any exposed aramid strands.
2. Tighten down connector housing until flush with threaded sleeve head. When the connector housing is completely tightened down, no threads will be visible.
3. Slide protective boot over retention sleeve.
4. Cleave fiber using Leviton's Versa-Cleave or scribing tool. Properly dispose of fiber debris. (**Figure 16**)
5. 12 μ m "AIR POLISH" FOR SINGLEMODE AND MULTIMODE FIBER - Begin by "Air Polishing" the connector with 12 μ m polishing film. Hold film at the edge with thumb and forefinger. Gently touch connector to film and rotate using approximately 18-20 one-inch circles to remove fiber stub. The scraping sound of the fiber on the film will cease when the air polish process is complete. Leviton's 12 μ m film is dark pink in color.
6. Hold a lint-free wipe across fingertips, then gently press the connector's endface against the wipe. Twist the connector in place to remove any debris. Do not drag the connector across the lint-free wipe. (**Figure 17**)
7. 3 μ m POLISH FOR SINGLEMODE AND MULTIMODE FIBER - Wipe the bottom surface of the polishing puck and the surface of the polishing pad with a 99% isopropyl alcohol.
8. Place 3 μ m film on the polishing pad, dull side up, then carefully set polishing puck on the film. Gently insert the connector into the puck, and trace 15-20 Figure 8's on the film, using very light pressure. Test to ensure fiber is complete polished.
9. Repeat steps 6 and 7 with the .3 μ m film. Leviton's 3 μ m film is yellow and .3 μ m film is light blue in color.

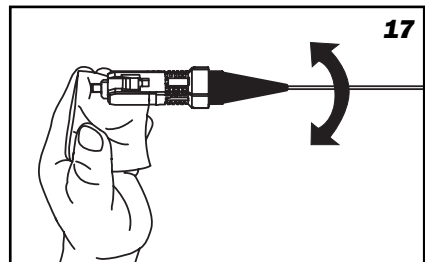
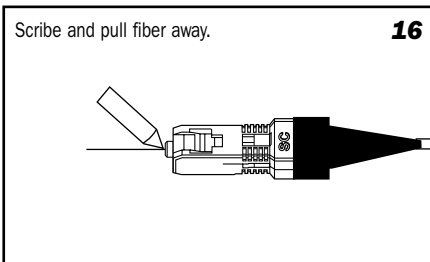
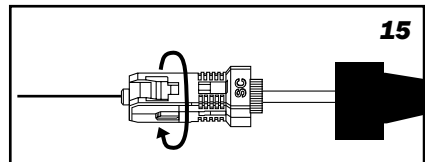
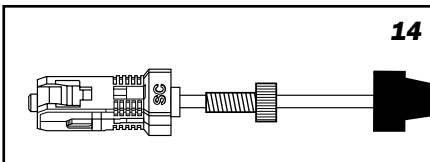

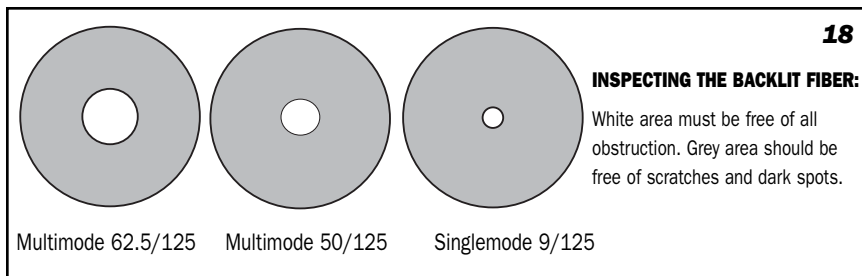

- 10.** Using a Leviton recommended 200x inspection scope, inspect the fiber to assure the fiber's core is not scratched, cracked or broken. Also check to ensure that fiber is polished flush by dragging gently across lint-free wipe. Fiber should not snag. If fiber snags, continue polishing. Remove any debris using a lint-free wipe. **(Figure 18)**

These are the tools included in both the 49800-UTK and 49800-UTP Fiber Optic Tool Kits which are necessary to complete a termination:

Jacket Stripper
900µm Buffer Remover
250µm Buffer Remover
Electrician Scissors (for cutting aramid yarn)
Scribing Tool (49800-UTK Only)
Versa-Cleave (49800-UTP Only)
Polishing Pad
Universal Polishing Puck
200X Inspection Scope
Safety Glasses
Piano Wire

These are the supplies included in the Universal Consumable Kit, which are necessary to complete a termination:

Lint-Free Wipes
99% Isopropyl Alcohol
12 micron Polishing Film (Dark Pink)
3 micron Polishing Film (Yellow)
0.3 micron Polishing Film (Light Blue)
Piano Wire